



Contents

Pages

3RM1 Compact - Hybrid Starters

Overview	6/2
General Data	6/3
Selection and ordering data	6/4
Accessories	6/5 - 6/8
Technical Data	6/9 - 6/10



Overview



3RM12 motor starter with reversing functionality and electronic overload protection

SIRIUS 3RM1 motor starters are compact devices with a width of 22.5 mm, combining a large number of functions in a single enclosure. They consist of combinations of relay contacts, power semiconductors (hybrid technology), and a solid-state overload relay for operational switching of three-phase motors up to 3 HP (at 480 V).

Feature	Value
Rated current (wide setting range of the electronic overload release)	0.1 ... 0.5 A 0.4 ... 2.0 A 1.6 ... 7.0 A (UL=6.1A)
Rated operational voltage	48 ... 500 V
Rated frequency	50/60 Hz
Rated control supply voltage	24 V DC, 110 V DC, 110 ... 230 V AC
Trip class	CLASS 10A

The 3RM1 motor starters with overload protection with wide setting range are offered as 3RM10 direct-on-line starters and 3RM12 reversing starters and as versions with safety-related shutdown.

Characteristic	3RM10	3RM11	3RM12	3RM13
Direct-on-line starters	✓	✓	--	--
Reversing starters	--	--	✓	✓
Overload protection with wide setting range	✓	✓	✓	✓
ATEX certification overload protection	--	✓	--	✓
Safety-related shutdown up to SIL 3 / PLe	--	✓	--	✓

Hybrid technology

The 3RM1 motor starters combine the benefits of semiconductor technology and relay technology. This combination is also known as hybrid technology. The hybrid technology in the motor starter is characterized by the following features:

- The inrush current is conducted briefly via the semiconductors.
Advantage: protection of relay contacts, long service life due to low wear
- The continuous current is conducted via relay contacts.
Advantage: lower heat losses compared with the semiconductor.
- Shutdown is implemented again via the semiconductor.
Advantage: the contacts are only slightly exposed to arcs, and this results in a longer service life.

Functional density/space savings

The 3RM1 motor starters combine the functions direct/reversing starting and overload protection and safety-related shutdown in a single device, without changing the 22.5mm width.

For simple applications (such as starting and reversing three-phase loads with overload protection), motor starter combinations of power contactors and a solid-state overload relay, for example, can be replaced by a single 3RM1 starter. The more functions are required, the more devices can be replaced. The footprint area required for each motor starter in the control cabinet is reduced by values of 64 to 82%.

In the case of assemblies and grouped starter units there are further advantages.

Wiring overhead

By combining various functions in a single device, wiring overhead is reduced. The greater the number of starters, the greater the saving in wiring. Savings can be made in:

- mains wiring and space reduction with the use of the 3RM19 three phase infeed system
- wiring of the reversing contactor assembly thanks to the integrated design
- reduction of control cables for the coils in group applications with the 3ZY12 device connectors

These savings reduce the time required for the wiring itself, while at the same time reducing both the risk of wiring errors and the amount of testing required after control cabinets have been completed.

Configuration and inventory

The wide setting range of the electronic overload release (up to 1:5) reduces the cost of inventory and the considerations involved in configuration where the actual motor current to be expected is concerned. Compared with protection equipment with thermal overload protection, only 3 versions are now required to cover a current range of 0.1 to 7 A with 3RM1, instead of 17 versions.

Connection methods

The 3RM1 is available with screw terminal, push-in terminals or a combination of both..

Push-in terminals are a form of spring-type connection allowing fast wiring without tools for rigid conductors or conductors equipped with end sleeves.

Fine-stranded or stranded conductors with no end finishing are wired using a screwdriver (with a 3.0 x 0.5 mm blade).

As with other spring-type terminals, a screwdriver is also required to release the conductor. The same tool as above can be used for this purpose.

The advantages of the push-in terminals are found, as with all spring-type terminals, in speed of assembly and disassembly and vibration-proof connection. There is no need for the checking and tightening required with screw terminals.



Screw terminals



Spring-type terminals

The terminals are indicated in the corresponding tables by the symbols shown on blue backgrounds.



Safety-related shutdown/safety integration

Thanks to the redundant design of the main circuit and internal monitoring, safety-related shutdown in accordance with SIL 3 / PLe is possible by shutting down the control supply voltage with 3RM11 Failsafe and 3RM13 Failsafe motor starters. Additional safety relays are not required in the main circuit.

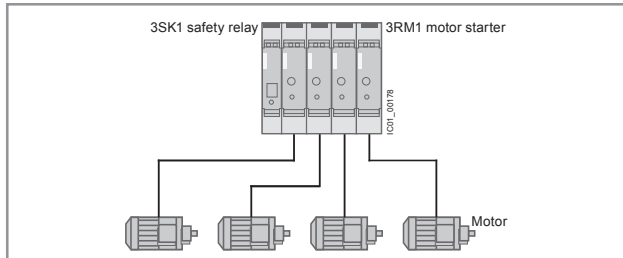

Combination of four SIRIUS 3RM1 Failsafe motor starters with SIRIUS 3SK1 safety relay to allow safety-related collective disconnection of connected motors

3RM1 motor starters are ideal for combining with the 3SK1 safety relay (see Chapter 13 "Safety Technology" → "SIRIUS 3SK1 Safety Relays"). They can be combined by means of:

- conventional wiring
- a special device connector

This makes it very simple to shut down connected motors collectively. The wiring, and ultimately the shutting down of the control supply voltage in Emergency Stop situations, is performed via the device connector. There is no further need for complex looping of the connecting cables.

Feedback to the control system

The electronic output in the 24 V DC control voltage version of the 3RM10 and 3RM12 motor starters allows the status of the connected motor to be reported to the higher-level control system. If the motor starter is controlled via inputs IN1 to 2, once the motor has been switched on and has started up correctly the output "OUT" is set.

Infeed system for the main circuit

The 3RM19 infeed system available as an accessory for the main circuit with three-phase busbars allows fast, virtually error-free wiring of motor starters on the mains connection side and may reduce the number of short-circuit protective devices.

Benefits

Advantages through energy efficiency

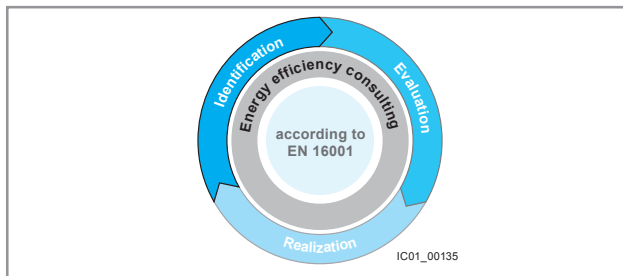

Overview of the energy management process

We offer you a unique portfolio for efficient industrial energy management, using an energy management system that helps to optimally define your energy needs. We split up our industrial energy management into three phases – identify, evaluate, and realize – and we support you with the appropriate hardware and software solutions in every process phase.

The innovative products of the SIRIUS Industrial Controls portfolio can also make a substantial contribution to a plant's energy efficiency (see www.siemens.com/sirius/energysaving).

With 3RM1 motor starters, control cabinets warm up less because power losses have been reduced by operation:

- Lower intrinsic power loss (than comparable motor starters with thermal overload trips) thanks to electronic current analysis
- Lower control circuit power losses (compared with conventional switching devices) as a result of electronic control of switching points
- Thanks to the above advantages, additional energy savings are possible because less cooling is required and a more compact design is possible

Product advantages

The SIRIUS 3RM1 motor starters offer a number of benefits:

- Greater endurance and reduced heat losses thanks to hybrid technology
- Less space required in the control cabinet (64 to 82%) as a result of higher functional density
- Less wiring and testing required as a result of integrating several functions into a single device
- Lower costs for stock keeping and configuration as a result of the wide setting range of the electronic overload release (up to 1:5)
- Fast wiring without tools for rigid conductors or conductors equipped with end sleeves thanks to push-in spring-type connections
- Motor status feedback to the higher-level control system in the case of 3RM10 and 3RM12 motor starters in the 24 V DC version
- Virtually error-free wiring on the mains connection side and reduction in short-circuit protective devices by means of 3RM19 comb busbar and infeed system

Compact – Hybrid Starters

Hybrid Starters

• Revised •
09/30/14

SIRIUS



3RM1 up to 3HP

Selection and ordering data

- Direct and reversing starters in 22.5mm width
- Electronic overload protection — class 10
- Coil voltages 24VDC, 110-230VAC and 110VDC
- Screw Terminals or Spring Loaded Terminals
- Group Installation possible with fuse or UL489 breaker
- SCCR up to 100kA with J fuses
- Comb busbar accessories for easy group assembly
- Removeable terminals

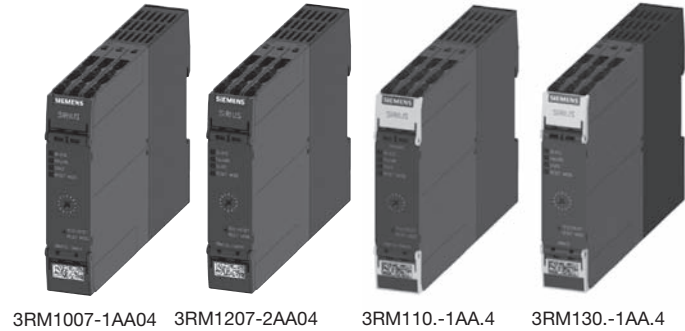

3RM10 motor starter for direct-on-line starting with electronic overload protection

with

UL ratings at 480VAC		Amp ratings		Single-phase HP ratings ^①			Three-phase HP ratings ^①			Signaling contacts		All Screw Terminals	All Spring Loaded Terminals	Mixed ^② Spring Loaded & Screw Terminals
FLA	LRA	AC53	AC51	115V	200V	230V	200V	230V	460V	NO	NC	Order No.	Order No.	Order No.
Rated control supply voltage $U_s = 24$ VDC														
0.5	3.5	0.5	—	—	—	—	—	—	—	1	1	3RM1□01-1AA04	3RM1□01-2AA04	3RM1□01-3AA04
2	14	2	—	—	—	1/8	1/3	1/3	3/4	1	1	3RM1□02-1AA04	3RM1□02-2AA04	3RM1□02-3AA04
6.1	43	7	10	1/4	1/2	1/2	1	1 1/2	3	1	1	3RM1□07-1AA04	3RM1□07-2AA04	3RM1□07-3AA04
Rated control supply voltage $U_s = 110-230$ VAC 50/60 Hz and 110 VDC														
0.5	3.5	0.5	—	—	—	—	—	—	—	1	1	3RM1□01-1AA14	3RM1□01-2AA14	3RM1□01-3AA14
2	14	2	—	—	—	1/8	1/3	1/3	3/4	1	1	3RM1□02-1AA14	3RM1□02-2AA14	3RM1□02-3AA14
6.1	43	7	10	1/4	1/2	1/2	1	1 1/2	3	1	1	3RM1□07-1AA14	3RM1□07-2AA14	3RM1□07-3AA14
												0	0	0
Standard DOL Starter												1	1	1
Safety DOL Starter														

3RM12 motor starter for reversing with electronic overload protection

with

UL ratings at 480VAC		Amp ratings		Single-phase HP ratings ^①			Three-phase HP ratings ^①			Signaling contacts		All Screw Terminals	All Spring Loaded Terminals	Mixed ^② Spring Loaded & Screw Terminals
FLA	LRA	AC53	AC51	115V	200V	230V	200V	230V	460V	NO	NC	Order No.	Order No.	Order No.
Rated control supply voltage $U_s = 24$ VDC														
0.5	3.5	0.5	—	—	—	—	—	—	—	1	1	3RM1□01-1AA04	3RM1□01-2AA04	3RM1□01-3AA04
2	14	2	—	—	—	1/8	1/3	1/3	3/4	1	1	3RM1□02-1AA04	3RM1□02-2AA04	3RM1□02-3AA04
6.1	43	7	10	1/4	1/2	1/2	1	1 1/2	3	1	1	3RM1□07-1AA04	3RM1□07-2AA04	3RM1□07-3AA04
Rated control supply voltage $U_s = 110-230$ VAC 50/60 Hz and 110 VDC														
0.5	3.5	0.5	—	—	—	—	—	—	—	1	1	3RM1□01-1AA14	3RM1□01-2AA14	3RM1□01-3AA14
2	14	2	—	—	—	1/8	1/3	1/3	3/4	1	1	3RM1□02-1AA14	3RM1□02-2AA14	3RM1□02-3AA14
6.1	43	7	10	1/4	1/2	1/2	1	1 1/2	3	1	1	3RM1□07-1AA14	3RM1□07-2AA14	3RM1□07-3AA14
												2	2	2
Standard Reversing Starter												3	3	3
Safety Reversing Starter														

For detail product manuals, schematics and CAD files:
<http://www.usa.siemens.com/3RM1>

① Selection depends on motor full load amps.
Horsepower ratings are for reference only.

② Mixed terminal versions have spring loaded terminals for the control wiring and screw terminals on the mains.

This offers faster control wiring while still being able to use the 3RM19 comb busbar system on the mains.

For accessories, see page 6/6 and 6/8

For technical data, see page 6/9 and 6/10

For additional Compact Starters up to 25HP at 480V, see the 3RA6 series located in section 4



Overview

Accessories for 3RM1 motor starters

The following accessories are available for the 3RM1 motor starter:

- 3-phase infeed system for the main circuit
- Device connectors for the control circuit
- Spare terminals for main and control circuits
 - With screw terminals
 - With push-in spring-type terminals
- Push-in lugs for wall mounting the motor starters
- Sealable cover as protection against unauthorized access

Three-phase infeed system (3RM19 three-phase busbar system)

Special three-phase busbar systems can be used to provide an easy, time-saving and safe means of feeding two or more 3RM1 motor starters with screw terminals.

These busbars are available in three lengths, thus allowing 2, 3 or 5 motor starters (arranged side-by-side) to be connected at the same time. More than 5 devices can be connected by clamping the connection tags of an additional busbar rotated by 180° (e.g. 6 devices using one 5-pole busbar and one 2-pole busbar).

A single motor starter can be removed from the assembly without loosening the terminal screws of neighboring motor starters.

The maximum summation current must not exceed 25 A. Primary infeed is connected via a three-phase infeed terminal.

The three-phase busbars are finger-safe but empty connection tags must be fitted with covers.

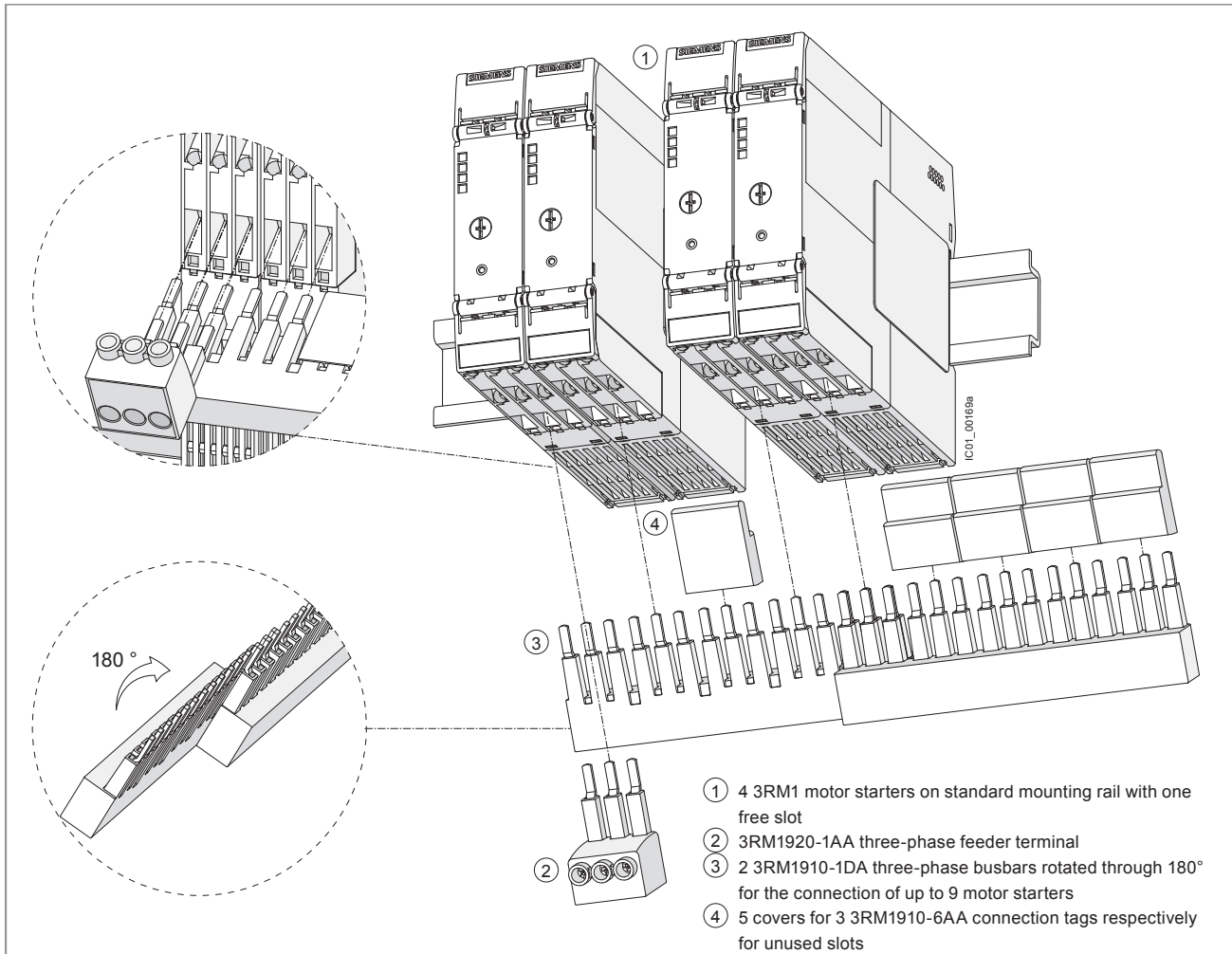

3RM19 infeed system with three-phase infeed terminal: In the above example, two three-phase busbars (5-pole busbars) rotated through 180° allow up to 9 3RM1 motor starters to be connected. Contact with the unused connection tags in unoccupied positions is prevented safely by the covers.

Compact - Hybrid Starters

SIRIUS 3RM1 Motor Starters



Accessories

Device connectors for the control circuit

The outlay for cabling between the devices is reduced using device connectors snapped onto a mounting rail, or screwed onto a level mounting panel (one device connector per motor starter).

Using the device connectors only for feeding in the control supply voltage

By using device connectors, several motor starters can be jointly supplied with a control supply voltage of 24 V DC. This requires the control supply voltage to be applied to the A1 and A2 terminals of only one motor starter.

Up to ten motor starters can be connected with device connectors. The 24 V DC control supply voltage must be within the operating range of 0.9 to 1.1 for this purpose. If the full operating range of 0.8 to 1.25 is to be used, no more than five motor starters can be used.

If the motor starters are not to be interconnected side-by-side, device daisy chain connectors must be used for the gaps.

When removing a motor starter, the corresponding device connector must be replaced by a device daisy chain connector if the control voltage is not to be interrupted for motor starters on the right.

The last motor starter in a row can be placed on a device termination connector. Flush termination of the configuration is thus possible.

Using device connectors in conjunction with 3SK1 safety relays

Interconnection of several Standard or Failsafe version motor starters into a group can also be used for joint disconnection by a 3SK1 safety relay.

To provide for the simultaneous and safe shutdown of several motor starters via a SIRIUS 3SK1 Safety Relay, you can simply interconnect the devices without additional wiring using a device connector.

The motors can then also be shut down safely according to SIL 3 / PLe with the motor starters.

Up to five motor starters can be operated on one safety relay with device connectors. If the motor starters are not to be interconnected side-by-side, device loop through connectors must be used for the gaps.

The last motor starter in a row must be placed on a device termination connector. This closes the circuits that were built up with the connectors.

For 3SK1 safety relays and associated device connectors see Chapter 13 "Safety Technology" → "SIRIUS 3SK1 Safety Relays"

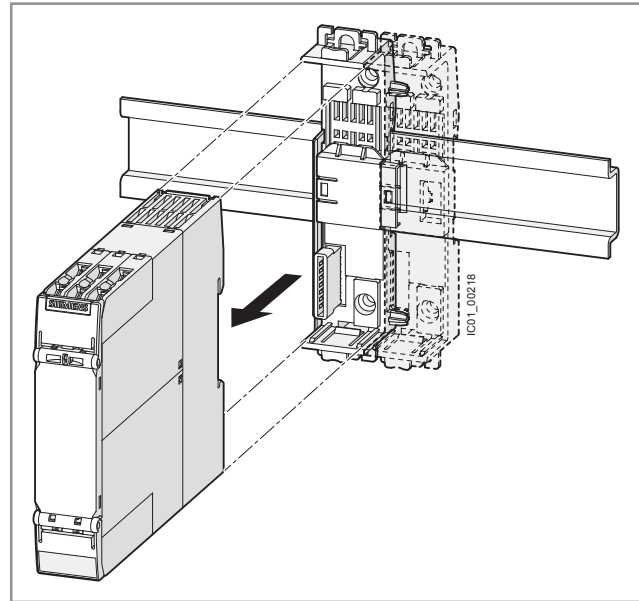

Device connectors snapped onto a standard mounting rail to allow the joint connection of the control supply voltage for 3RM1 motor starters or connection to the 3SK1 safety relays

Usage restrictions for accessories

- The 3RM19 3-phase infeed system for the main circuit can only be used with 3RM1 motor starters with screw terminals.
- The device connectors are only suitable for 3RM1 motor starters with a control supply voltage of 24 V DC.



Selection and ordering data

		Order No.	Pack Units
Device connectors for busing the control supply connection to 3RM1 Starters			
	Device connector type 2, 7-pole, 22.5mm Use for: <ul style="list-style-type: none"> • Beginning left hand connector • Subsequent positions where a starter is present • Maximum of five starters per system 	3ZY1212-2EA00	1
	Device loop through connector type 2, 7-pole, 22.5mm Use for: <ul style="list-style-type: none"> • When 22.5mm spacing is required and no starter is present 	3ZY1212-2AB00	1
	Device termination connector type 2, 7-pole, 22.5mm Use for: <ul style="list-style-type: none"> • Terminating connector for the right hand position • Terminating cover is assembled to 3ZY1212-2EA00 	3ZY1212-2FA00	1

		Screw Terminals	Spring Terminals	Pack Units
		Order No.	Order No.	
Removable terminals for 3RM1 Starters				
	Power Terminals (Line and Load) 2-pole, 12-20 AWG	3ZY1122-1BA00	3ZY1122-2BA00	6
	Control Terminals 3-pole, 14-20 AWG (Screw) 3-pole, 14-16 AWG (Spring)	3ZY1131-1BA00	3ZY1131-2BA00	6

Further accessories

	Push-in lugs for wall mounting 2 lugs per starter are required. Standard pack quantity is sufficient for 5 starters	3ZY1311-0AA00	10
	Seal covers for 3RM1 starters Protection of current setting dial. - lockable	3ZY1321-2AA00	5
	Cooling pins for removable terminals For mechanical coding of removable terminals	3ZY1440-1AA00	

For detail product manuals, schematics and CAD files:
<http://www.usa.siemens.com/3RM1>



Compact – Hybrid Starters

3RM1 Hybrid Starters

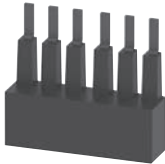
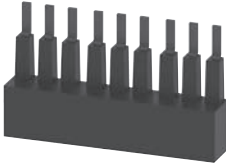
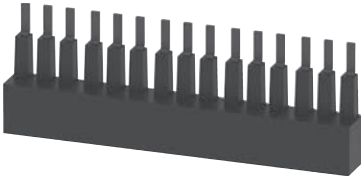

3RM1 Accessories

Selection and ordering data

Type	Version	Order No.	Pack
3RM19 three-phase infeed system for 3RM1 starters with screw terminals on the mains			
 <p>Three-phase feeder terminal</p>		3RM1920-1AA	1
 <p>Three-phase busbar system</p>	For 2 motor starters	3RM1910-1AA	1
	For 3 motor starters	3RM1910-1BA	1
	For 5 motor starters	3RM1910-1DA	1
 <p>Protective covers For finger safety / yellow</p>	For unused slots	3RM1910-6AA	1



Application

3RM1 motor starters are designed for applications in which small motors have to be connected in the most confined spaces.

Main areas of use

- Conveyor systems
- Logistics systems
- Production machines
- Machine tools
- Small elevators

Standards and approvals

The motor starter complies with the following standards:

- IEC/EN 60947-4-2
- UL 508
- ATEX (available soon)
- IEC 61508-1: SIL 3 (available soon)
- ISO 13849: PLe (available soon)

Technical specifications

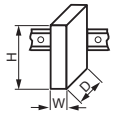
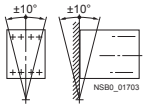
Type	3RM1	
Mechanical components and environment		
Dimensions (W x H x D)		
• Width	mm	22.5
• Height	mm	100
• Depth	mm	136.5 (from the standard mounting rail) 141.6 (entire enclosure depth)
		
Ambient temperature		
• During operation	°C	-25 ... +60
• During storage	°C	-40 ... +70
• During transport	°C	-40 ... +70
Installation altitude at height above sea level maximum	m	4 000
Shock resistance		6g/11 ms
Vibration resistance		1 ... 6 Hz, 15 mm; 20 m/s ² , 500 Hz
IP degree of protection		IP20
Mounting position		
		
Electromagnetic compatibility (EMC)		
Emitted interference		
• Conducted RF interference emission according to CISPR11		Class A for Industrial applications. Class B for residential, business and commercial applications.
• Non-conducted RF interference emission according to CISPR11		Class A for industrial applications. Class B for residential, business and commercial applications.
Interference immunity		
• Electrostatic discharge according to IEC 61000-4-2		4 kV contact discharge / 8 kV air discharge
• Conducted interference injection as high frequency interference according to IEC 61000-4-6		10 V
• Conducted interference BURST according to IEC 61000-4-4		2 kV / 5 kHz
• Conducted interference - phase-to-ground SURGE according to IEC 61000-4-5		2 kV
• Conducted interference - phase-to-phase SURGE according to IEC 61000-4-5		1 kV

Type	3RM1 .01	3RM1 .02	3RM1 .07
Main circuit			
Rated operational voltage maximum	V	500	
Operating frequency			
• 1 rated value	Hz	50	
• 2 rated value	Hz	60	
Rated insulation voltage	V	600	
Rated impulse withstand voltage	kV	6	
Rated operational current at 400 V at AC	A	0.5	2
Active power loss, typical	W	0.02	0.3
Minimum load in % of I_M	%	20	7 ¹⁾
Adjustable current response value			
• of the inverse-time delayed overload release	A	0.1 ... 0.5	0.4 ... 2
			1.6 ... 7 ¹⁾

¹⁾ UL rating is 6.1A at 480V

Compact – Hybrid Starters

SIRIUS 3RM1 Motor Starters



Technical data

Type		3RM1 ...-AA04	3RM1 ...-AA14
Control circuits			
Type of voltage of the control supply voltage		DC	AC/DC
Control supply voltage 1			
• At DC	V	24	110
• At 50 Hz			
- At AC	V	—	110 ... 230
Frequency of the control supply voltage			
• 1 rated value	Hz	—	50
• 2 rated value	Hz	—	60
Operating range factor of the control supply voltage rated value			
• At DC		0.8 ... 1.25	0.85 ... 1.1
• At 50 Hz			
- At AC		—	0.85 ... 1.1
Control current		A	0.08
Input voltage at the digital input			
• At DC	V	24	110
• At AC	V	—	110 ... 230
- Rated value			
Input voltage at the digital input with signal <1>			
• At DC	V	19.2 ... 30	93 ... 121
• At AC	V	—	93 ... 253
Input current at the digital input with signal <1> typical		A	0.01

Type		3RM1...-14	3RM1...-24
Connection methods			
Connectable conductor cross-section for main contacts			
• Solid	mm ²	0.5 ... 4	
• Finely stranded			
- With end sleeves	mm ²	0.5 ... 2.5	
- Without end sleeves	mm ²	—	0.5 ... 4
Connectable conductor cross-section for auxiliary contacts			
• Solid	mm ²	0.5 ... 2.5	0.5 ... 1.5
• Finely stranded			
- With end sleeves	mm ²	0.5 ... 2.5	0.5 ... 1
- Without end sleeves	mm ²	—	0.5 ... 1.5
AWG number as coded connectable conductor cross-section			
• For main contacts		20 ... 12	
• For auxiliary contacts		20 ... 14	20 ... 16

Note:

All the above technical specifications are relevant for selecting the motor starters. Details about installation conditions and the use of the motor starters, and particularly about the derating of the rated current, can be found in the manual and the data sheets located at www.usa.siemens.com/3RM1.