

Contents	Pages
UL and CSA file and guide numbers	19/2
On-line References for Industrial Control Products	19/3
General Information	
NEMA enclosure descriptions	19/4
IEC enclosure descriptions	19/5
IEC contactor utilization categories	19/6
Control circuit classifications	19/7
Ampere ratings for 3 phase AC induction motors	19/8
Metric to US conversions	19/9
Electical formulas and grounding requirements	19/10
NEMA and IEC terminal markings	19/11
Electrical symbols	19/12
Control circuit schematics	19/13
Control circuit schematics and wiring diagrams	19/14
Pilot control	19/15
International Control Equipment	
Quick reference list	19/16
Spring Loaded Terminal Technique	19/17
Standard Terms & Conditions of Sale	19/18

Appendix

Standards and Approvals

UL and CSA file numbers and guide card numbers

Most control equipment listed in this catalog is designed, manufactured and tested in accordance with the relevant UL and CSA standards as listed on pages 19/2 and 19/3.

Equipment	SEC	CSA		UL-listed			UL-recognized		
		Guide No.	File No.	Guide No.	c®	File No.	Guide No.	c®	File No.
3RV motor starter protectors	1	Class 3211 05	LR 12730	NLRV	NLRV7	E 47705	-	-	-
3RV as self-protected controller (Type E)	1	Class 3211 08	LR 12730	NKJH	NKJH7	E 156943	-	-	-
3RV17, 18, 27 & 28 as circuit breakers	1	Class 1432 01	LR 12730	DIVQ	DIVQ7	E 235044	-	-	-
3RA13 & 23 reversing contactors	2	Class 3211 04	LR 12730	NLDX	NLDX7	E 31519	NLDX2	NLDX8	E 31519
3RH control relays	2	Class 3211 03	LR 12730	NKCR	NKCR7	E 44653	-	-	-
3RT contactors	2	Class 3211 04	LR 12730	NLDX	NLDX7	E 31519	NLDX2	NLDX8	E 31519
3TB contactors	2	Class 3211 04	LR 12730	NLDX	NLDX7	E 31519	NLDX2	-	E 31519
3TC4 DC Contactors	2	-	-	NLDX	NLDX7	E 31519	-	-	-
3TC5 DC Contactors	2	-	-	NLDX	-	E 31519	-	-	-
3TF6 contactors	2	Class 3211 04	LR 12730	NLDX	NLDX7	E 31519	NLDX2	-	E 31519
3TX7 surge suppressors	2	Class 3211 03	LR 12730	-	-	-	NKCR2	NKCR8	E 31519
3RB20 / 21 solid-state overload relay	3	Class 3211 03	LR 12730	NKCR	NKCR7	E 44653	-	-	-
3RB22, 23 & 24 solid-state overload relay	3	Class 3211 03	LR 12730	NKCR	NKCR7	E 44653	-	-	-
3RB30 / 31 solid-state overload relay	3	-	-	NKCR	NKCR7	E 44653	-	-	-
3RU11 & 21 thermal overload relay	3	Class 3211 03	LR 12730	NKCR	NKCR7	E 44653	-	-	-
3RU21 thermal overload relay	3	-	-	NKCR	NKCR7	E 44653	-	-	-
3UF7 SIMOCODE intelligent overload relay	3	Class 3211 03	LR 12730	NKCR	NKCR7	E 44653	-	-	-
3RA*1 & *2 combination starters	4	Class 3211 05	LR12730	NLDX	NLDX7	E 31519	-	-	-
3RA6 compact starter as manual motor controller	4	Class 3211 05	LR 12730	NLRV	NLRV7	E 47705	-	-	-
3RA6 compact starter as self protected controller (Type E)	4	Class 3211 08	LR 12730	NKJH	NKJH7	E 156943	-	-	-
8US1 busbar components	5	-	-	NMTR	NMTR7	E328403	-	-	-
8US1 busbar adapter shoes	5	²⁾	²⁾	-	-	-	NMTR2	NMTR8	E 328403
FB busbar adapter system	5	²⁾	²⁾	-	-	-	NMTR2	NMTR8	E 160776
3RM1 hybrid motor starter	6	-	-	NMFT	NMFT7	E 143112	-	-	-
3RW30 Soft starters	7	Class 3211 06	LR 12730	NMFT	NMFT7	E 143112	-	-	-
3RW30/31 Soft starters	7	Class 3211 06	LR 12730	NMFT	NMFT7	E 143112	-	-	-
3RW40/44 Soft starters	7	Class 3211 06	-	NMFT	NMFT7	E 143112	-	-	-
73 enclosed soft starters	7	-	-	NJAV	NJAV7	E 43399	-	-	-
74 combination soft starters	7	-	-	NJAV	NJAV7	E 43399	-	-	-
3RF20, 21 & 22	8	-	-	NMFT	NMFT7	E 143112	NRNT2	NRNT8	E44653
3RF23 & 24	8	-	-	NRNT	NRNT7	E44653	-	-	-
3RF24 & 34 solid-state contactors	8	Class 3211 07	LR12730	NMFT	-	E 143112	-	-	-
11 manual starters	9	Class 3211	LR 6535	NLVR	NLVR7	E 10590	-	-	-
14, 22, 30, 40, 43 starters & contactors	9	Class 3211	LR 6535	NLDX	NLDX7	E 14900	-	-	-
17, 18, 25, 26, 32 combination starters	9	Class 3211	LR 6535	NKJH	NKJH7	E 185287	-	-	-
36, 37 reduced voltage starters	9	Class 3211	LR 6535	NLDX	NLDX7	E 14900	-	-	-
83, 84, 85, 87, 88 pump control panels	9	Class 3211	LR 6535	NKJH	NKJH7	E 185287	-	-	-
48, 958 overload relays ESP200	9	Class 3211 03	LR 12730	NKCR	NKCR7	E 44653	-	-	-
49 field kits	9	Class 3211	ELR 535	NLDX	-	E 14900	NLDX2	-	E 14900
CLM lighting contactors	9	-	-	NRNT	NRNT7	E 27683	-	-	-
LC lighting contactors - open	9	-	-	NLDX	NLDX7	E 14900	-	-	-
LC lighting contactors - enclosed	9	-	-	NRNT	NRNT7	E 27683	-	-	-
LEN00B, C, D, E lighting - open	9	-	-	NLDX	-	E 31519	-	-	-
LEN00F, G, H, lighting - open	9	-	-	NRNT	NRNT7	E 27683	-	-	-
LE lighting contactors - enclosed	9	-	-	NRNT	NRNT7	E 27683	-	-	-
MMS manual switches	9	-	-	NLRV	-	E10590	NLRV2	-	E 10590
SMF manual starters	9	-	-	NLRV	-	E10590	NLRV2	-	E 10590
3SB2 16mm pushbuttons and indicator lights	10	Class 3211 03	LR 12730	-	-	-	NKCR2	-	E 44653
3SB3 22mm pushbuttons and indicator lights	10	Class 3211 03	LR 12730	NKCR	NKCR7	E 44653	-	-	-
50 standard duty pilot devices	10	Class 3211	LR 6535	NKCR	NKCR7	E 22655	NKCR2	NKCR8	E 22655
51 hazardous location pilot devices	10	Class 3218	LR 23889	NOIV	NOIV7	E 39935	-	-	-
52 30 mm pilot devices	10	Class 3211	LR 6535	NKCR	NKCR7	E 22655	-	-	-
8WD signal columns	10	-	-	NMTR	NMTR7	E 148698	-	-	-
3RN1 thermistor motor protection	11	Class 3211 03	LR 12730	NKCR	NKCR7	E 44653	-	-	-
3RP1 electronic time-delay relay	11	Class 3211 03	LR 12730	NKCR	NKCR7	E 44653	-	-	-
3RS10, 11, 20 & 21 temperature monitoring relay	11	-	-	NKCR	NKCR7	E 44653	-	-	-
3RS17 interface converter	11	¹⁾	¹⁾	NKCR	NKCR7	E 44653	-	-	-

¹⁾ c® listing for Canada, instead of CSA certification.

²⁾ c® recognition for Canada, instead of CSA certification.

Appendix Standards and Approvals

UL and CSA file numbers and guide card numbers On-line resources for Industrial Control products

Equipment	CSA ®	CSA		UL-listed ® c®			UL-recognized ® c®		
		Guide No.	File No.	Guide No.	c®	File No.	Guide No.	c®	File No.
3RS18 coupling relays	11			NKCR	NKCR7	E 44653			
3TG10 power relay	11	¹⁾	¹⁾	NLDX	NLDX7	E 31519			
3TX70 coupling devices	11	Class 2211 03	LR 12730	NKCR	NKCR7	E 44653	NKCR2	NKCR8	E 44653
3TX71 plug-in relays	11	–	–	–	–	–	NLDX2	NLDX8	E 14900
3TX71 sockets	11	–	–	–	–	–	SWIV2	SWIV8	E 196786
3UG monitoring relay	11	¹⁾	¹⁾	NKCR	NKCR7	E 44653	–	–	–
7PV time-delay relay	11	Class 2211 03	LR 12730	NKCR	NKCR7	E 44653	–	–	–
8WA1 Terminal blocks	12	–	–	–	–	–	XCFR2	–	E 80027
8WA2 & 8WH Terminal blocks	12	Class 3211	LR50181	–	–	–	XCFR2	XCFR8	E 80027
3SK1 safety relays	13			NKCR	NKCR7	E 44653			
3RK3 MSS	13	Class 3211 03	LR 12730	NKCR	NKCR7	E 44653	–	–	–
3SE03 North American (NEMA) limit switches	13	–	–	NKCR	–	E 47512	–	–	–
3SE2 hinge switches	13			NKCR	NKCR7	E 44653			
3SE5 limit switches	13	Class 3211 03	LR 12730	NKCR	NKCR7	E 44653	NKCR2	NKCR8	E 44653
3SE6 magnetic monitoring system	13			NKCR	NKCR2	E 44653			
3SE7 rope pull switches	13	¹⁾	¹⁾	NKCR	–	E 44653	–	–	–
3SK1 safety relays	13								
3TK28 safety relay	13	¹⁾	¹⁾	NKCR	NKCR7	E 44653	–	–	–
AS-Interface components for control circuits, e.g. AS-Interface modules, gateways	14	Class 3211 03	LR 12730	NKCR	NKCR7	E 44653	–	–	–
AS-Interface components for power cir-cuits, e.g. AS-Interface motor starters, PROFIBUS motor starters	14	Class 3211 04	LR 12730	NLDX	NLDX7	E 31519	–	–	–
6ED1 programmable relays	15			NRAQ	NRAQ7	E 217227			
6EP1 DC power supplies	15	¹⁾	¹⁾	NRAQ	NRAQ7	E 143289	NRAQ2	NRAQ8	E 143289
6GK5 ethernet switches	15			NWGQ	NWGQ7	E 115352			
5SJ4 circuit breakers	16	–	–	DIVQ	DIVQ7	E 243414	–	–	–
5ST Aux switch, fault signal contact, shunt trip, busbar	16	–	–	DIHS	DIHS7	E 321559	DIHS2	DIHS8	E 321559
5SY4 supplementary protectors	16	²⁾	²⁾	–	–	–	QVNU2	QVNU8	E 116386
3NW70 Fuse Holder	16	–	–	–	–	–	IZLT2	IZLT8	E 171267
3NW75 Class CC Fuse Holder	16	–	–	IZLT	IZLT7	E 171267	–	–	–
Sentron circuit breakers	17	Class 1432-01	LR 13077	DIVQ	DIVQ7	E 10848	DKPU2	–	³⁾ E10848
VL circuit breakers	17	Class 1432-01	LR 13077	DIVQ	DIVQ7	E 10848	DKPU2	–	³⁾ E10848
WL circuit breakers	17	–	–	DIVQ	DIVQ7	E 231263	–	–	–
3LD2 disconnect switches	18	¹⁾	230576	NLRV	NLRV7	E 47705	–	–	–
CFS fusible disconnect switches	18	–	222227	WHY2	–	E 121152	WHY2	–	E 121152
LBR and LBT disconnect switches	18	–	¹⁾	NLRV	–	E 191706	–	–	–
MCS disconnect switches	18	–	154852	–	–	–	WHY2	–	E 121152
VBL disconnect switches	18	–	154852	–	–	–	WHY2	–	E 121152
VBL safety switches	18	–	⁴⁾	WIAX	WIAX7	E 4776	–	–	–

¹⁾ c ® listing for Canada, instead of CSA certification.

²⁾ c ® recognition for Canada, instead of CSA certification.

³⁾ Instantaneous only circuit breakers (ETI or MCP).

⁴⁾ CSA labeled SWS available on request.

On-Line Resources for Industrial Control Products

Controls Website

- with links to all sites listed below plus much more

www.usa.siemens.com/controls

Siemens Industrial Controls Catalog

- with updates to the print Catalog

www.usa.siemens.com/iccatalog

Siemens Industry Mall

- Quickly search for Siemens control products
- Configure products for your application
- Create and export a complete Bill of Material for your system
- Find helpful technical information, such as:
* Instruction Sheets & Manuals
* 2D & 3D Dimension Drawings

www.usa.siemens.com/industrymall

Industrial Control Panels for North America

- Learn the secrets of control panel design
- Improve efficiency in construction and operation of your control panels

www.usa.siemens.com/controlpaneldesign

Short Circuit Current Ratings (SCCR) to meet UL508A & NEC

- Find the latest High Short Circuit testing for combinations of Siemens Power Distribution & Control Products

<http://www.usa.siemens.com/sccr>

Siemens Service and Support Website

- Get answers to technical and application questions
- Receive training on the latest innovations

<http://support.automation.siemens.com/US>

Appendix

General Information

NEMA enclosure descriptions

NEMA Standard Publications

No. 250-1979

Type 1

Type 1 enclosures are intended for indoor use primarily to provide a degree of protection against contact with the enclosed equipment in locations where unusual service conditions do not exist. The enclosures shall meet the rod entry and rust resistance design tests.

Type 3

Type 3 enclosures are intended for outdoor use, primarily to provide a degree of protection against wind-blown dust, rain and sleet, and to be undamaged by the formation of ice on the enclosure. They shall meet rain, external icing, dust, and rust resistance design tests. They are not intended to provide protection against conditions such as internal condensation or internal icing.

Type 3R

Type 3R enclosures are intended for outdoor use, primarily to provide a degree of protection against falling rain, and to be undamaged by the formation of ice on the enclosure. They shall meet rod entry, rain, external icing, and rust resistance design tests. They are not intended to provide protection against conditions such as dust, internal condensation, or internal icing.

Type 4

Type 4 enclosures are intended for indoor or outdoor use, primarily to provide a degree of protection against windblown dust and rain, splashing water, and hose directed water, and to be undamaged by the formation of ice on the enclosure. They shall meet hosedown, external icing, and rust resistance design tests. They are not intended to provide protection against conditions such as internal condensation or internal icing.

Type 4X

Type 4X enclosures are intended for indoor or outdoor use, primarily to provide a degree of protection against corrosion, windblown dust and rain, splashing water, and hose-directed water, and to be undamaged by the formation of ice on the enclosure. They shall meet hosedown, external icing, and corrosion resistance design tests. They are not intended to provide protection against conditions such as internal condensation or internal icing.

Shall be manufactured of American Iron and Steel Institute Type 304 Stainless steel, polymerics, or materials with equivalent corrosion resistance to provide a degree of protection against specific corrosive agents.

Type 6

Type 6 enclosures are intended for indoor or outdoor use, primarily to provide a degree of protection against the entry of water during occasional temporary submersion at a limited depth.

Type 6P enclosures are intended for indoor or outdoor use primarily to provide a degree of protection against the entry of water during prolonged submersion at a limited depth.

Type 7

Type 7 enclosures are for indoor use in locations classified as Class I, Groups C or D, as defined in the National Electrical Code.

Type 7 enclosures shall be capable of withstanding the pressures resulting from an internal explosion of specified gases and contain such an explosion sufficiently that an explosive gas-air mixture existing in the atmosphere surrounding the enclosure will not be ignited. Enclosed heat generating devices shall not cause external surfaces to reach temperatures capable of igniting explosive gas-air mixtures in the

surrounding atmosphere. Enclosures shall meet explosion, hydrostatic, and temperature design tests.

Type 9

Type 9 enclosures are intended for indoor use in locations classified as Class II Groups E, F or G, as defined in the National Electrical Code.

Type 9 enclosures shall be capable of preventing the entrance of dust. Enclosed heat generating devices shall not cause external surfaces to reach temperatures capable of igniting or discoloring dust on the enclosure or igniting dust-air mixtures in the surrounding atmosphere. Enclosures shall meet dust penetration and temperature design tests, and aging of gaskets (if used).

Class I—Flammable gases or vapors.

Class II—Combustible dust.

Class III—Ignitable fibers or flyings.

Division I—Normal situation; the hazard would be expected to be present in everyday repair and maintenance.

Division II—Abnormal situation; the material is expected to be confined within closed containers or closed systems and will be present only during accidental rupture, breakage or unusual faulty operation.

Groups

Class I—Gases and vapors are designed for use in groups C and D, depending on the ignition temperature of the substance, its explosion pressure and other flammable characteristics.

Class II—Dust locations are designed for use in groups E, F, and G, according to the ignition temperature and conductivity of the hazardous substance.

Type 12

Type 12 enclosures are intended for indoor use primarily to provide a degree of protection against dust, falling dirt, and dripping non-corrosive liquids. They shall meet drip, dust, and rust resistance design tests. They are not intended to provide protection against conditions such as internal condensation.

Siemens NEMA 12 may be field modified for outdoor use. NEMA 3 requires the use of watertight conduit hubs. NEMA 3R requires the use of watertight conduit hubs at a level above the lowest live part and drain holes of 1/8" diameter shall be added at the bottom of the enclosure.

Type 13

Type 13 enclosures are intended for indoor use primarily to provide a degree of protection against dust, spraying of water, oil and non-corrosive coolant. They shall meet oil explosion and rust resistance design tests. They are not intended to provide protection against conditions such as internal condensation.



Type 1



Type 3/3R



Type 4/4X



Type 4X



Type 3, 4, 7 & 9



Type 12 & 13

Comparison of NEMA Enclosures

This table summarizes the information provided on the previous page.

Provides a Degree of Protection Against the Following Environmental Conditions	1	3R	4	4X	12	13
Incidental contact with the enclosed equipment	x	x	x	x	x	x
Rain, snow, and sleet	—	x	x	x	—	—
Windblown dust	—	—	x	x	—	—
Falling dirt	x	—	x	x	x	x
Falling liquids and light splashing	—	—	x	x	x	x
Circulating dust, lint, fibers, and flyings	—	—	x	x	x	x
Settling airborne dust, lint, fibers, and flyings	—	—	x	x	x	x
Hosedown and splashing water	—	—	x	x	—	—
Oil and coolant seepage	—	—	—	—	x	x
Oil or coolant spraying and splashing	—	—	—	—	—	x
Corrosive agents	—	—	—	x	—	—

IEC Environmental Enclosure Ratings for Global Applications

IEC enclosures use a two digit numbering system to define the degree of protection they provide. The first digit specifies the degree of protection against incidental contact and penetration of solid objects. The second digit specifies the level of protection against the ingress of water.

Example: An IP65 enclosure is dust tight and protected against water jets. An IP66 enclosure is dust tight and protected against powerful water jets.

First Numeral	Second Numeral
Protection of persons against access to hazardous parts and protection against penetration of solid foreign objects.	Protection against ingress of water under test conditions specified in IEC 529.
0 Non-protected	0 Non-protected
1 Back of hand; objects greater than 50 mm in diameter	1 Vertically falling drops of water
2 Finger; objects greater than 12.5 mm in diameter	2 Vertically falling drops of water with enclosure tilted 15 degrees
3 Tools or objects greater than 2.5 mm in diameter	3 Spraying water
4 Tools or objects greater than 1 mm in diameter	4 Splashing water
5 Dust-protected (Dust may enter but must not interfere with operation of the equipment or impair safety)	5 Water jets
6 Dust tight (No dust observable inside enclosure at end of test)	6 Powerful water jets
	7 Temporary submersion
	8 Continuous submersion

Comparison of NEMA Type Numbers to IEC Classification Designations

This table shows the IP classification designation to which NEMA enclosures may be applied. The table cannot be used to convert IEC designations to NEMA type numbers.

NEMA Enclosure Type Number	IEC Enclosure Classification Designation
1	IP10
3	IP54
3R	IP54
4 and 4X	IP56
6 and 6P	IP67
12	IP52
13	IP54

Appendix

General Information

IEC contactor utilization categories

Contactors designed for international applications are tested and rated per IEC 947-4. The IEC rating system is broken down into different utilization categories that define the value of the current that the contactor must make, maintain, and break. The following category definitions are the most commonly used for IEC Contactors.

Ratings for Siemens contactors per these categories can be found in Section 3.

AC Categories

AC-1

This applies to all AC loads where the power factor is at least 0.95. These are primarily non-inductive or slightly inductive loads. Breaking remains easy.

AC-3

This category applies to squirrel cage motors where the breaking of the power contacts would occur while the motor is running. On closing, the contactor experiences an inrush which is 5 to 8 times the nominal motor current, and at this instant, the voltage at the terminals is approximately 20% of the line voltage. Breaking remains easy.

AC-4

This applies to the starting and breaking of a squirrel cage motor during an inch or plug reverse. On energization, the contactor closes on an inrush current approximately 5 to 8 times the nominal current. On de-energization, the contactor breaks the same magnitude of nominal current at a voltage that can be equal to the supply voltage. Breaking is severe.

DC Categories

DC-1

This applies to all DC loads where the time constant (L/R) is less than or equal to one msec. These are primarily noninductive or slightly inductive loads.

DC-2

This applies to the breaking of shunt motors while they are running. On closing, the contactor makes the inrush current around 2.5 times the nominal rated current. Breaking is easy.

DC-3

This applies to the starting and breaking of a shunt motor during inching or plugging. The time constant shall be less than or equal to 2 msec. On energization, the contactor sees current similar to that in Category DC-2. On de-energization, the contactor

will break around 2.5 times the starting current at a voltage that may be higher than the line voltage. This would occur when the speed of the motor is low because the back e.m.f. is low. Breaking is severe.

DC-5

This applies to the starting and breaking of a series motor during inching or plugging. The time constant being less than or equal to 7.5 msec. On energization, the contactor sees about 2.5 times the nominal full load current. On de-energization, the contactor breaks the same amount of current at a voltage which can be equal to the line voltage. Breaking is severe.

Special Contactor Utilization Categories

Some contactors also have ratings for the following specialty utilization categories.

For specific applications, please contact your local Siemens sales office.

Kind of Current	Utilization Categories	Typical Applications
AC	AC-2	Slip-ring motors: starting, switching off
	AC-5a	Switching of electric discharge lamp controls
	AC-5b	Switching of incandescent lamps
	AC-6a	Switching of transformers, welders
	AC-6b	Switching of capacitor banks
	AC-7a	Slightly inductive loads in household appliances and similar applications
	AC-7b	Motor-loads for household applications
	AC-8a AC-8b	Hermetic refrigerant compressor motor ¹⁾ control with manual resetting of overload releases Hermetic refrigerant compressor motor ¹⁾ control with automatic resetting of overload releases
DC	DC-6	Switching of incandescent lamps

Electrical Quantities Symbols According to DIN, VDE and IEC

Symbol	Characteristic Electrical Quantity	Symbol	Characteristic Electrical Quantity
U_i	Rated insulation voltage to DIN VDE 0110/DIN VDE 0660	I_{sw}	Rated short-time current withstand capacity to IEC 947-1
U_e	Rated operational voltage	$I_{p,n}$	Test current (general) to DIN VDE 0660, prospective current to DIN VDE 0636
U_c	Rated control voltage (IEC 947-1) at which an operating mechanism or release is rated, e.g. coil voltage to DIN VDE 0660 Part 102	$I_{p,n}$	Breaking current (r.m.s. value) to DIN VDE 0102
U_s	Rated control supply voltage (Control voltage) to DIN VDE 0660 Part 102, IEC 947-1	$i_{p,k}$	Peak short-circuit current (maximum instantaneous value) to DIN VDE 0102
U_n	No-load voltage to IEC 947-2, -3, -5	$I_{p,k}$	Sustained (symmetrical) short-circuit current (r.m.s. value), DIN VDE 0102.
U_r	Power-frequency recovery voltage (IEC 947-.)	$I_{p,k}$	Rated short-time withstand current to DIN VDE 0660
U_o	Transformer no-load voltage to DIN VDE 0532	i_p	Let-through current of fuses and rapidly operating switching devices (maximum instantaneous value during the break time) to DIN VDE 0102
U_k	Short-circuit impedance voltage to DIN VDE 0532	I_o	No-load current at the input side of a transformer (unloaded output side) to DIN VDE 0532
U_{kr}	Rated value of the impedance voltage in % to DIN VDE 0102, 01.90	I_x	Current carrying capacity (ampacity)
I_n	Rated current to IEC 947-.	I_{sr}	Rated rotor operational current (DIN VDE 0660, IEC 947-1)
I_{th}	Eight-hour-current to DIN VDE 0660, conventional free-air thermal current to IEC 947- (defined as eight-hour-current) thermally equivalent short-time current (r.m.s. value) to DIN VDE 0103	I_r	Setting current ("current setting") to DIN VDE 0660
I_{the}	Conventional enclosed thermal current	I_B	Take-over current
I_u	Rated uninterrupted current to IEC 947-1	R	Ohmic resistance
I_e	Rated operational current	S''_k	Initial symmetrical AC short-circuit power (simplified: apparent short-circuit power)
I_s	Selectivity (discrimination) limit current (DIN VDE 0660, IEC 947-1)	X	Reactance, reactive impedance
I_{cm}	Rated short-circuit making capacity to IEC 947-1	Z	Impedance (apparent resistance)
I_{cn}	Rated short-circuit breaking capacity to IEC 947-1	x	Factor to determine the peak short-circuit current ip
I_{cm}	Rated ultimate short-circuit breaking capacity to IEC 947-1		

1) Hermetic refrigerant compressor motor is a combination consisting of a compressor and a motor, both of which are enclosed in the same housing, with no external shaft or shaft seals, the motor operating in the refrigerant.

NEMA and IEC control circuit classifications

AC-Control Circuit Classifications—NEMA

NEMA designates Control Circuit Rating with a code letter (for current) and a voltage code.

Ratings & Test Values for AC Control Circuit Contacts at 50 or 60Hz

Contact Rating Designation	Thermal Continuous Test Current, Amperes	Maximum Current, Amperes								Voltamperes	
		120 Volts		240 Volts		480 Volts		600 Volts			
		Make	Break	Make	Break	Make	Break	Make	Break	Make	Break
A150	10	60	6	—	—	—	—	—	—	7200	720
A300	10	60	6	30	3	—	—	—	—	7200	720
A600	10	60	6	30	3	15	1.5	12	1.2	7200	720
B150	5	30	3	—	—	—	—	—	—	3600	360
B300	5	30	3	15	1.5	—	—	—	—	3600	360
B600	5	30	3	15	1.5	7.5	0.75	6	0.6	3600	360
C150	2.5	15	1.5	—	—	—	—	—	—	1800	180
C300	2.5	15	1.5	7.5	0.75	—	—	—	—	1800	180
C600	2.5	15	1.5	7.5	0.75	3.75	0.375	3	0.3	1800	180
D150	1	3.6	0.6	—	—	—	—	—	—	432	72
D300	1	3.6	0.6	1.8	0.3	—	—	—	—	432	72
E150	0.5	1.8	0.3	—	—	—	—	—	—	216	36

DC-Control Circuit Classifications—NEMA

Rating codes for DC Control Circuit Contacts

Contact Rating Designation ¹⁾	Thermal Continuous Test Current, Amperes	Maximum Make or Break ²⁾ Current, Amperes			Maximum Make or Break Voltamperes at 300 Volts or Less
		125 Volt	250 Volt	301 to 600 Volt	
		N150	10	2.2	
N300	10	2.2	1.1	—	275
N600	10	2.2	1.1	0.4	275
P150	5	1.1	—	—	138
P300	5	1.1	0.55	—	138
P600	5	1.1	0.55	0.2	138
Q150	2.5	0.55	—	—	69
Q300	2.5	0.55	0.27	—	69
Q600	2.5	0.55	0.27	0.1	69
R150	1	0.22	—	—	28
R300	1	0.22	0.11	—	28

Control Circuit Classifications—IEC³⁾

IEC 947-5-1 Uses Utilization Categories AC-15 to Specify Control Circuit Ranges.

Current at each voltage is specified by the manufacturer, not by the standard.

AC Control Circuit Utilization Categories per IEC 947-5-1	Make		Break		DC Control Circuit Utilization Categories per IEC 947-5-1	Make		Break	
	I _e /I _e	U _e /U _e	I _e /I _e	U _e /U _e		I _e /I _e	U _e /U _e	I _e /I _e	U _e /U _e
AC-12	1	1	1	1	DC-12	1	1	1	1
AC-13	2	1	1	1	DC-13	1	1	1	1
AC-14	6	1	1	1	DC-14	10	1	1	1
AC-15	10	1	1	1					

Example of a Typical IEC Control Circuit Ratings Table⁴⁾

AC			DC		
I _e /AC-12 (Continuous Amps)	U _e AC Voltage	I _e /AC-15 Amps	Voltage	I _e /DC-12	I _e /DC-13
10	24V	6A	24	6A	3A
	110V	6A	60	5A	1.5A
	220/230V	6A	110	2.5A	0.7A
	380/440V	4A	230	1A	0.3A

1)The numerical suffix designates the maximum voltage design values, which are to be 600, 300, and 150 volts for suffixes 600, 300, and 150 respectively. Test voltage shall be 600, 250, or 125 volts. MLLDLL.

2)For maximum ratings at 300 volts or less, the maximum make and break ratings are to be obtained by dividing the volt-ampere rating by the application voltage, but the current value is not to exceed the thermal continuous test current.

3) I_e Rated operational current
U_e Rated operational voltage
I Current to be made or broken
U Voltage before make

4)Example: A control circuit contact having an AC-15 rating of 6 amps at 230 volts is capable of making 60 amps and breaking 6 amps at 230 volts. KRE.

1
2
3
4
5
6
7
8
9
10
11
12
13
14
15
16
17
18
19

Appendix

General Information

Ampere ratings for 3 phase AC induction motors

3 Phase

Amperes 60Hz					
Hp	Syn Speed RPM	200 Volts	230 Volts	460 Volts	575 Volts
¼	1800	1.09	0.95	0.48	0.38
	1200	1.61	1.40	0.70	0.56
	900	1.84	1.60	0.80	0.64
⅓	1800	1.37	1.19	0.60	0.48
	1200	1.83	1.59	0.80	0.64
	900	2.07	1.80	0.90	0.72
½	1800	1.98	1.72	0.86	0.69
	1200	2.47	2.15	1.08	0.86
	900	2.74	2.38	1.19	0.95
¾	1800	2.83	2.46	1.23	0.98
	1200	3.36	2.82	1.46	1.17
	900	3.75	3.26	1.63	1.30
1	3600	3.22	2.80	1.40	1.12
	1800	4.09	3.56	1.78	1.42
	1200	4.32	3.76	1.88	1.50
1 ½	900	4.95	4.30	2.15	1.72
	3600	5.01	4.36	2.18	1.74
	1800	5.59	4.86	2.43	1.94
2	1200	6.07	5.28	2.64	2.11
	900	6.44	5.60	2.80	2.24
	3600	6.44	5.60	2.80	2.24
3	1800	7.36	6.40	3.20	2.56
	1200	7.87	6.84	3.42	2.74
	900	9.09	7.90	3.95	3.16
5	3600	9.59	8.34	4.17	3.34
	1800	10.8	9.40	4.70	3.76
	1200	11.7	10.2	5.12	4.10
7 ½	900	13.1	11.4	5.70	4.55
	3600	15.5	13.5	5.76	5.41
	1800	16.6	14.4	7.21	5.78
10	1200	18.2	15.8	7.91	6.32
	900	18.3	15.9	7.92	6.33
	3600	22.4	19.5	9.79	7.81
15	1800	24.7	21.5	10.7	8.55
	1200	25.1	21.8	10.9	8.70
	900	26.5	23.0	11.5	9.19
20	3600	29.2	25.4	12.7	10.1
	1800	30.8	25.8	13.4	10.7
	1200	32.2	28.0	14.0	11.2
30	900	35.1	30.5	15.2	12.2
	3600	41.9	36.4	18.2	14.5
	1800	45.1	39.2	19.6	15.7
40	1200	47.6	41.4	20.7	16.5
	900	51.2	44.5	22.2	17.8
	3600	58.0	50.4	25.2	20.1
50	1800	58.9	51.2	25.6	20.5
	1200	60.7	52.8	26.4	21.1
	900	63.1	54.9	27.4	21.9

Amperes 60Hz					
Hp	Syn Speed RPM	200 Volts	230 Volts	460 Volts	575 Volts
25	3600	69.9	60.8	30.4	24.3
	1800	74.5	64.8	32.4	25.9
	1200	75.4	65.6	32.8	26.2
30	900	77.4	67.3	33.7	27.0
	3600	84.8	73.7	36.8	29.4
	1800	86.9	75.6	37.8	30.2
40	1200	90.6	78.8	39.4	31.5
	900	94.1	81.8	40.9	32.7
	3600	111	96.4	48.2	38.5
50	1800	116	101	50.4	40.3
	1200	117	102	50.6	40.4
	900	121	105	52.2	41.7
60	3600	138	120	60.1	48.2
	1800	143	124	62.2	49.7
	1200	145	126	63.0	50.4
75	900	150	130	65.0	52.0
	3600	164	143	71.7	57.3
	1800	171	149	74.5	59.4
100	1200	173	150	75.0	60.0
	900	177	154	77.0	61.5
	3600	206	179	89.6	71.7
125	1800	210	183	91.6	73.2
	1200	212	184	92.0	73.5
	900	222	193	96.5	77.5
150	3600	266	231	115	92.2
	1800	271	236	118	94.8
	1200	275	239	120	95.6
200	900	290	252	126	101
	3600	—	292	146	116
	1800	—	293	147	117
250	1200	—	298	149	119
	900	—	305	153	122
	3600	—	343	171	137
300	1800	—	348	174	139
	1200	—	350	174	139
	900	—	365	183	146
400	3600	—	458	229	184
	1800	—	452	226	181
	1200	—	460	230	184
500	900	—	482	241	193
	3600	—	559	279	223
	1800	—	568	284	227
600	1200	—	573	287	229
	900	—	600	300	240
	3600	—	278	339	271
700	1800	—	684	342	274
	1200	—	684	342	274
800	1800	—	896	448	358
	1800	—	896	448	358

Full load ampere ratings of motors vary depending upon a number of factors. The full load currents listed above are “average values” for horsepower rated motors of several manufacturers at the most commonly rated voltages and speeds. These “average values” along with the similar values listed in the N.E.C. should be used as a guide only for selecting suitable components for the motor branch circuit. The rated full load current shown on the motor nameplate

may vary considerably from the listed value, depending on the specified motor design.

Note: RPM shown for 60Hz motors. For 50Hz motors, multiply the 60Hz FLA value by 1.2.

Overload Relay Selection Multi-Speed/Part-Winding/Wye-Delta

Special attention should be given to the selection of the overload relay adjustment range for multi-speed, part-winding and wye-delta controllers, as follows:

Multi-Speed Controllers: Each speed requires a separate set of overloads. The adjustment range must be selected on the basis of the full-load current for each particular speed.

Part-Winding Controllers: Each winding of the motor must have its own set of overloads. The adjustment range should be selected on the basis of one-half the motor full-load current; that is, the full load current of each winding current.

Wye-Delta Controllers: Only one set of overloads is required. Since the overload relay is located electrically “inside the delta connection,” the adjustment range must be selected on the basis of the full-load motor current (delta connection) divided by 1.73.

Single Phase: See page 9/120 for ampere ratings of single phase AC induction motors.

Wire Conversion Table

Other Conversions

Comparison of Cross-sectional Areas to Metric and US Standards

Metric Cross-sectional Areas (in line with VDE)		American Wire Gauge	
Cross-sectional Area mm ²	Equivalent Metric C.S.A. mm ²	AWG or MCM	
0.75	0.635	19 AWG	
	0.823	18	
	1.04	17	
1.5	1.31	16	
	1.65	15	
	2.08	14	
2.5	2.62	13	
	3.31	12	
4	4.17	11	
	5.26	10	
6	6.63	9	
	8.37	8	
	10.55	7	
10	13.30	6	
	16.77	5	
16	21.15	4	
	26.67	3	
25	33.63	2	
	42.41	1	
35	53.48	1/0	
	67.43	2/0	
50	85.03	3/0	
	107.20	4/0	
70	126.64	250 MCM	
	152.00	300	
95	177.35	350	
	202.71	400	
120	253.35	500	
	304.00	600	
185	354.71	700	
	405.35	800	
240	506.71	1000	
300			
400			
500			
625			

Power Conversions

1 kilowatt (kW)	=	1.341 horsepower (hp)
-----------------	---	-----------------------

1 horsepower (hp)	=	0.7457 kilowatt (kW)
-------------------	---	----------------------

Dimensions Conversions

1 inch (in.)	=	25.4 millimeters (mm)
--------------	---	-----------------------

1 inch (in.)	=	2.54 centimeters (cm)
--------------	---	-----------------------

1 centimeter (cm)	=	0.3937 inches (in.)
-------------------	---	---------------------

1 meter (m)	=	39.37 inches (in.)
-------------	---	--------------------

Weight Conversions

1 ounce (oz.)	=	28.35 grams (g)
---------------	---	-----------------

1 pound (lb.)	=	0.454 kilograms (kg)
---------------	---	----------------------

1 kilogram (kg)	=	2.205 pounds (lbs.)
-----------------	---	---------------------

Temperature Conversions

100 Celsius	=	212 Fahrenheit
-------------	---	----------------

80 Celsius	=	176 Fahrenheit
------------	---	----------------

60 Celsius	=	140 Fahrenheit
------------	---	----------------

40 Celsius	=	104 Fahrenheit
------------	---	----------------

20 Celsius	=	68 Fahrenheit
------------	---	---------------

0 Celsius	=	32 Fahrenheit
-----------	---	---------------

Torque

1 Newton-meter (Nm)	=	8.85 pound-inches (lb. in.)
---------------------	---	-----------------------------

Appendix

General Information

Electrical formulas and grounding requirements

Electrical Formulas for Finding Amperes, Horsepower, Kilowatts and kVA

To Find	Single-Phase	Alternating Current Two-Phase ¹⁾ , Four-Wire	Three-Phase	Direct Current
Kilowatts	$\frac{I \times E \times pf}{1000}$	$\frac{I \times E \times 2 \times pf}{1000}$	$\frac{I \times E \times 1.73 \times pf}{1000}$	$\frac{I \times E}{1000}$
kVA	$\frac{I \times E}{1000}$	$\frac{I \times E \times 2}{1000}$	$\frac{I \times E \times 1.73}{1000}$	—
Horsepower (Output)	$\frac{I \times E \times \% \text{ EFF} \times pf}{746}$	$\frac{I \times E \times 2 \times \% \text{ EFF} \times pf}{746}$	$\frac{I \times E \times 1.73 \times \% \text{ EFF} \times pf}{746}$	$\frac{I \times E \times \% \text{ EFF}}{746}$
Amperes when Horsepower is Known	$\frac{HP \times 746}{E \times \% \text{ EFF} \times pf}$	$\frac{HP \times 746}{2 \times E \times \% \text{ EFF} \times pf}$	$\frac{HP \times 746}{1.73 \times E \times \% \text{ EFF} \times pf}$	$\frac{HP \times 746}{E \times \% \text{ EFF}}$
Amperes when Kilowatts is Known	$\frac{KW \times 1000}{E \times pf}$	$\frac{KW \times 1000}{2 \times E \times pf}$	$\frac{KW \times 1000}{1.73 \times E \times pf}$	$\frac{KW \times 1000}{E}$
Amperes when kVA is Known	$\frac{kVA \times 1000}{E}$	$\frac{kVA \times 1000}{2 \times E}$	$\frac{kVA \times 1000}{1.73 \times E}$	—

Average Efficiency and Power Factor Values of Motors

When the actual efficiencies and power factors of the motors to be controlled are not known, the following approximations may be used.

Efficiencies³⁾

Type	Power Factor
DC motors, 35 horsepower and less	80% to 85%
DC motors, above 35 horsepower	85% to 90%
Synchronous motors (at 100% power factor)	92% to 95%
"Apparent" Efficiencies (= Efficiency × Power Factor); Three-phase induction motors, 25 horsepower and less	70%
Three-phase induction motors above 25 horsepower	80%

Fault-Current Calculation on Low-Voltage AC Systems

In order to determine the maximum interrupting rate of the circuit breakers in a distribution system, it is necessary to calculate the current which could flow under a three-phase bolted short circuit condition. For a three-phase system the maximum available fault current at the secondary side of the transformer can be obtained by use of the formula:

$$I_{sc} = \frac{kVA \times 100}{KV \times \sqrt{3} \times \% Z}$$

where:

I_{sc} = Symmetrical RMS amperes of fault current.

kVA = Kilovolt-ampere rating of transformers.

KV = Secondary voltage in kilovolts.

% Z = Percent impedance of primary line and transformer.

Minimum Size Grounding Conductors for Grounding Raceways and Equipment (From NEC Table 250-95²⁾)

Rating or Setting of Automatic Overcurrent Device in Circuit Ahead of Equipment, Conduit etc., Not Exceeding (Amperes)	Size	
	Copper Wire Number	Aluminum or Copper Clad Aluminum Wire Number
15	14	12
20	12	10
30	10	8
40	10	8
60	10	8
100	8	6
200	6	4
300	4	2
400	3	1
500	2	1/0
600	1	2/0
800	1/0	3/0
1000	2/0	4/0
1200	3/0	250 kcmil
1600	4/0	350 kcmil
2000	250 kcmil	400 kcmil
2500	350 kcmil	600 kcmil
3000	400 kcmil	600 kcmil
4000	500 kcmil	800 kcmil
5000	700 kcmil	1200 kcmil
6000	800 kcmil	1200 kcmil

Grounding Electrode Conductor for AC Systems (From NEC Table 250-94²⁾)

Size of Largest Service Entrance Conductor or Equivalent Area for Parallel Conductors		Size of Grounding Electrode Conductor	
Copper	Aluminum or Copper Clad Aluminum	Copper	Aluminum or Copper Clad Aluminum
2 or smaller	1/0 or smaller	8	6
1 or 1/0	2/0 or 3/0	6	4
2/0 or 3/0	4/0 or 250 kcmil	4	2
Over 3/0 to 350 kcmil	Over 250 kcmil to 500 kcmil	2	1/0
Over 350 kcmil to 600 kcmil	Over 500 kcmil to 900 kcmil	1/0	3/0
Over 600 kcmil to 1100 kcmil	Over 900 kcmil to 1750 kcmil	2/0	4/0
Over 1100 kcmil	Over 1750 kcmil	3/0	250 kcmil

1)In three-wire, two-phase circuits the current in the common conductor is 1.41 times that in either other conductor.

E = Volts I = Amperes
% EFF = Percent Efficiency pf = Power Factor

2)Additional information and exceptions are stated in Article 250—Grounding, National Electric Code.

3)These figures may be decreased slightly for single-phase and two-phase induction motors.

Symbols and Terminal Markings—IEC

Per DIN standards, the terminals of auxiliary contacts on contactors and control devices are marked with a two digit number. Terminals that belong together are marked with the same location digit (first digit).

The second digits (called the function digits) identify the function of each contact per the following designation.

Type of Contact	Function Digits
Normally Open	3 and 4
Normally Closed	1 and 2
Normally Open (Special Function)	5 and 6 i.e. Time-Delay or Overload
Normally Closed (Special Function)	
	7 and 8 Contacts

Example:

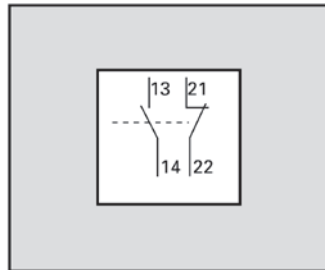

1. The numbers 13 and 14 represent an auxiliary contact
2. The number 1 identifies that this is the first contact in the sequence
3. The numbers 3 and 4 identify this as a normally open contact
4. The numbers 21 and 22 represent another auxiliary contact
5. The number 2 identifies that this is the second contact in the sequence
6. The numbers 1 and 2 identify this as a normally closed contact

Symbols and Terminal Markings

Control Circuits	NEMA	IEC
Normally Open (NO)		
Normally Closed (NC)		
Time Delay Circuits		
On Delay Normally Open (Timed Closed)		
Normally Closed (Timed Open)		
Off Delay Normally Open (Timed Open)		
Normally Closed (Timed Closed)		

NEMA and IEC Comparisons Contactor/Starter Markings

	NEMA		IEC
Coils		M — Defined by type of coil. No Standard terminal designation.	
Power Contacts 3-Pole Device		Line Side Connections	
Overload Relay		Line Side Connections	
		Load Side Connections	

Control Circuit Schematic

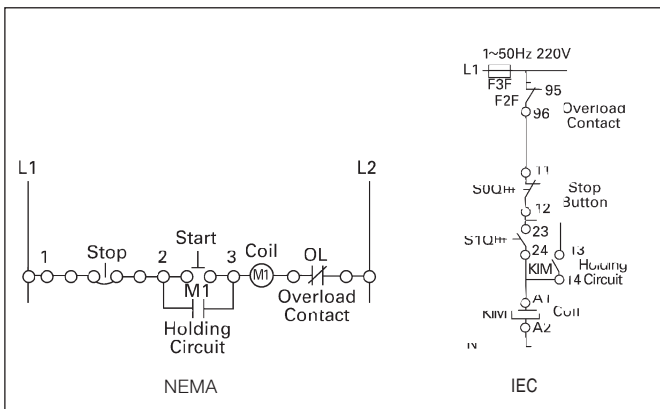

Power Circuit Schematic

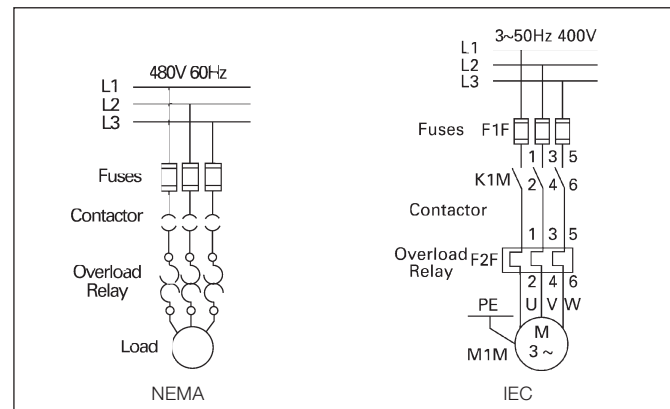

Appendix

General Information

Electrical symbols

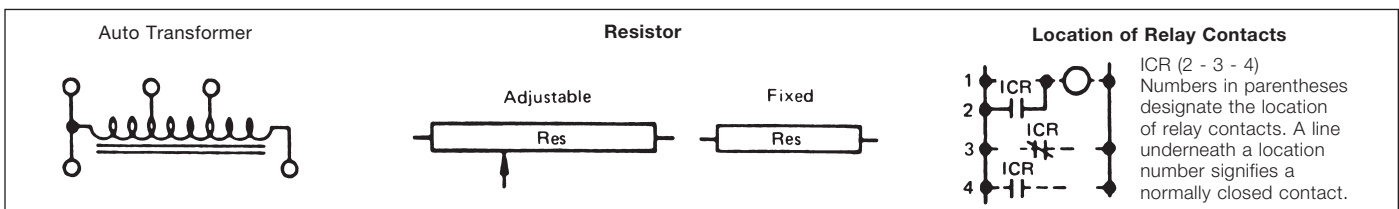
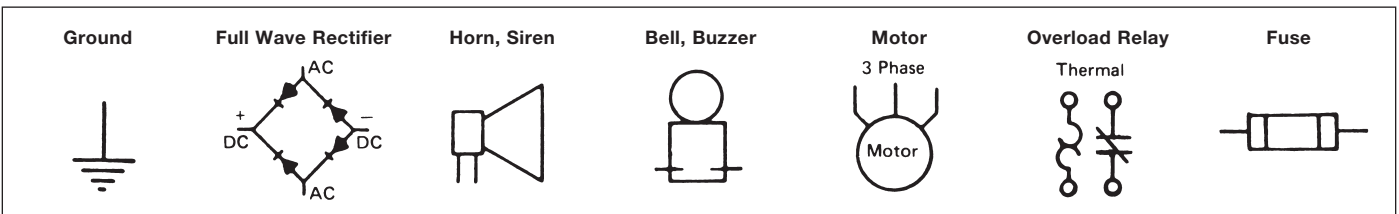
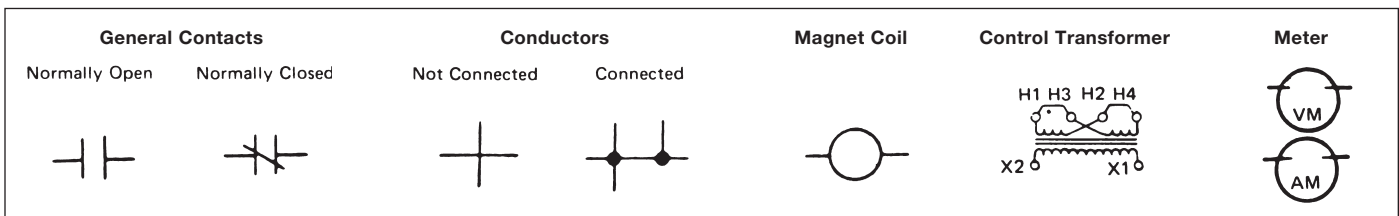
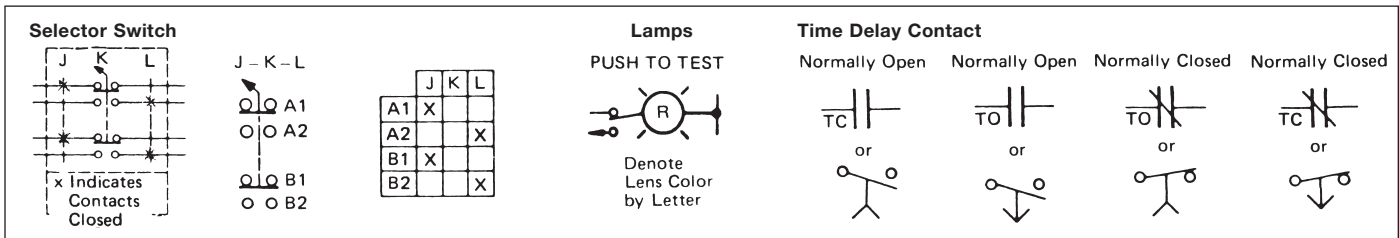
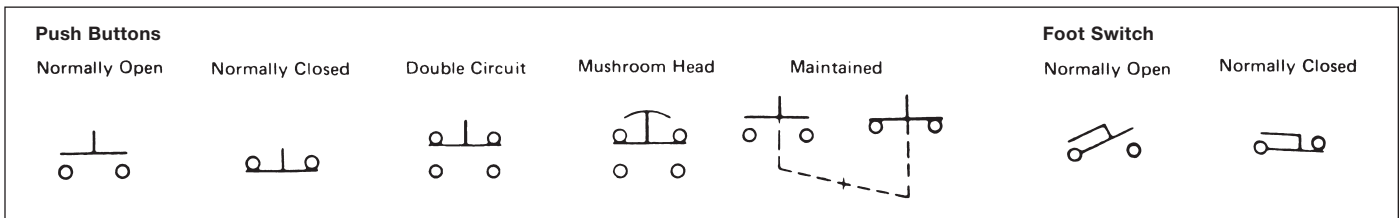
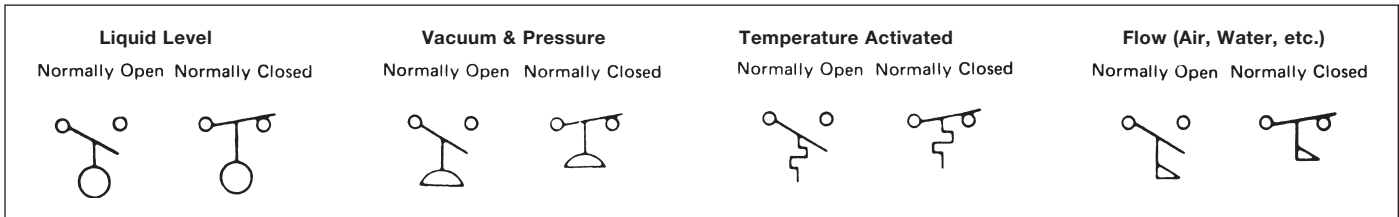
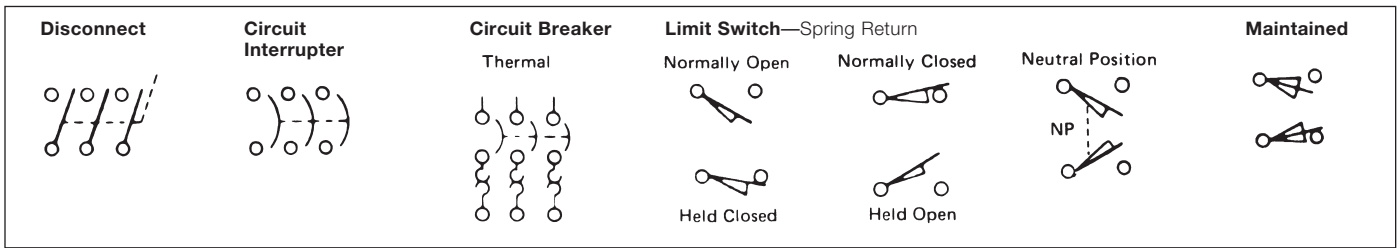

Figure 1 Three Wire Control Giving Low Voltage Protection Using Single Two Button Station

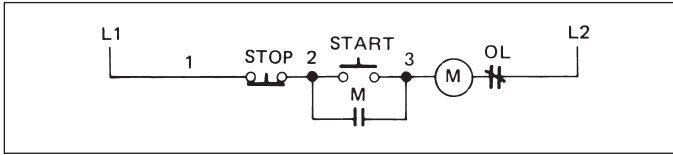

Figure 2 Three Wire Control Giving Low Voltage Protection Using Multiple Two Button Stations

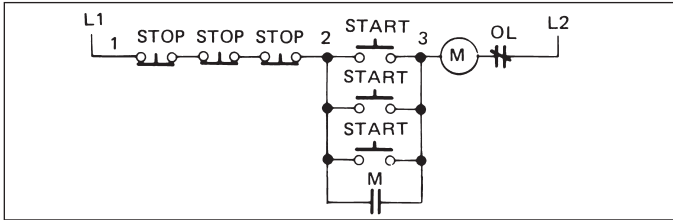

Figure 3 Three Wire Control Giving Low Voltage Protection with Safe-Run Selector Switch

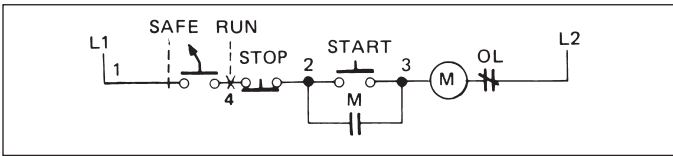

Figure 4 Three Wire Control for Jog or Run Using Start Stop Push Buttons and Jog-Run Selector Switch

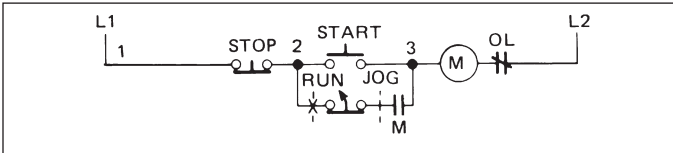

Figure 5 Control for Jog or Run Using Stop Push Button and Jog-Run Selector Push Selector Switch. Selector Push Contacts are Shown for "Run" (Three Wire Operation). Rotate Switch Sleeve and Selector Contact Opens Between "2" and "Stop" Button (Two Wire Operation)

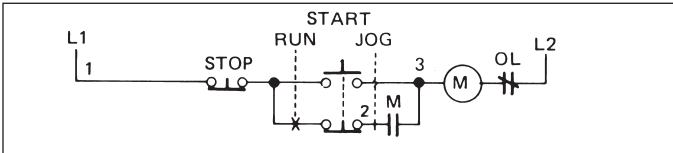

Figure 6 Three Wire Control for Jogging, Start, Stop Using Push Buttons

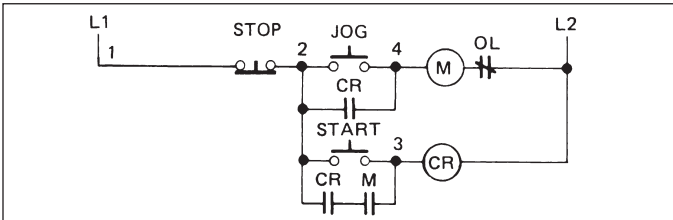

Figure 7 Two Wire Control Giving Low Voltage Release Only Using Hand-Off-Auto Selector Switch

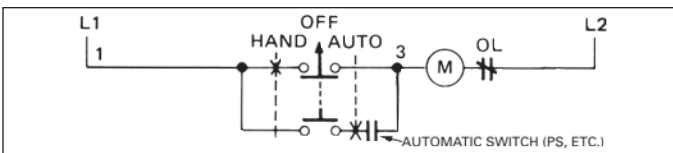

Figure 8 Two Wire Control for Reversing Jogging Using Single Two Button Station

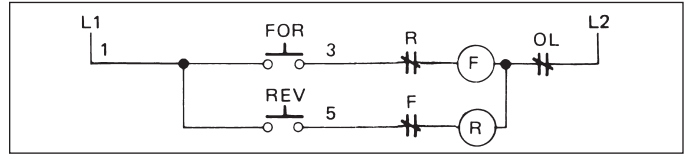

Figure 9 Three Wire Control for Instant Reversing Applications Using Single Three Button Station

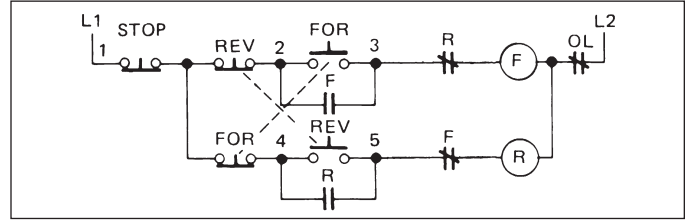

Figure 10 Three Wire Control for Reversing After Stop Using Single Three Button Station

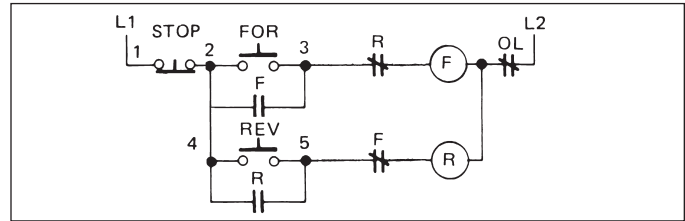

Figure 11 Control for Three Speed with Selective Circuitry to Insure the Stop Button is Pressed Before Going to a Lower Speed

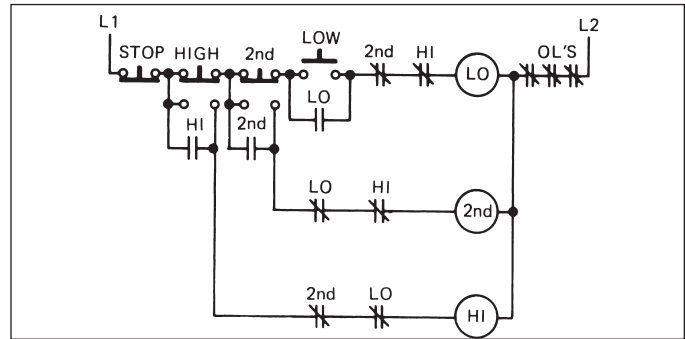
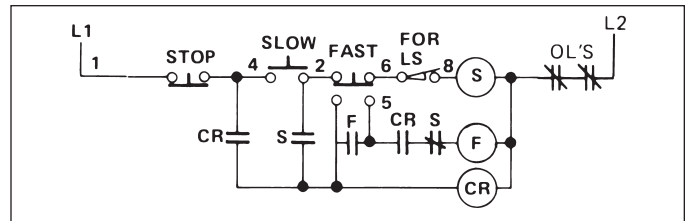
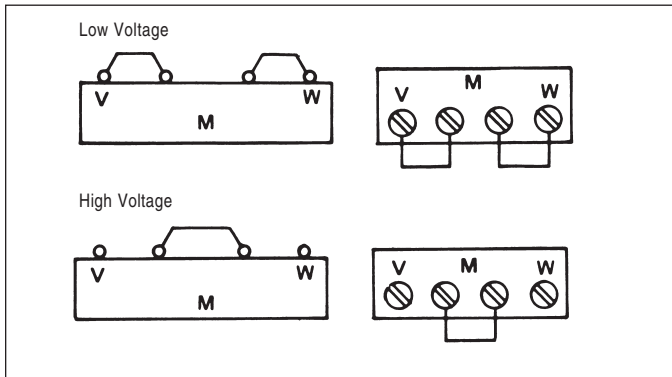

Figure 12 Three Wire Control for Two Speed with a Compelling Relay to Insure Starting on Slow Speed



AC Coil—NEMA Size 0-4



DC Coil—NEMA Size 0-4

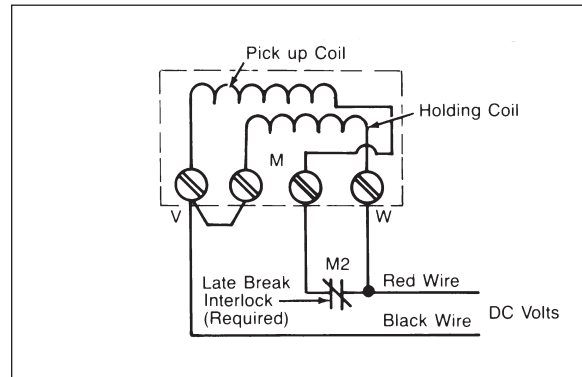

Non Reversing Pilot Control Terminal Markings shown in () indicate IEC Style. For separate control voltage source remove Jumper A shown individual in wiring diagrams. Connect separate voltage source to terminal 1 on the pilot device as shown and to the terminal **X2** on the overload relay, or **W(A2)** on the coil if there is no overload.

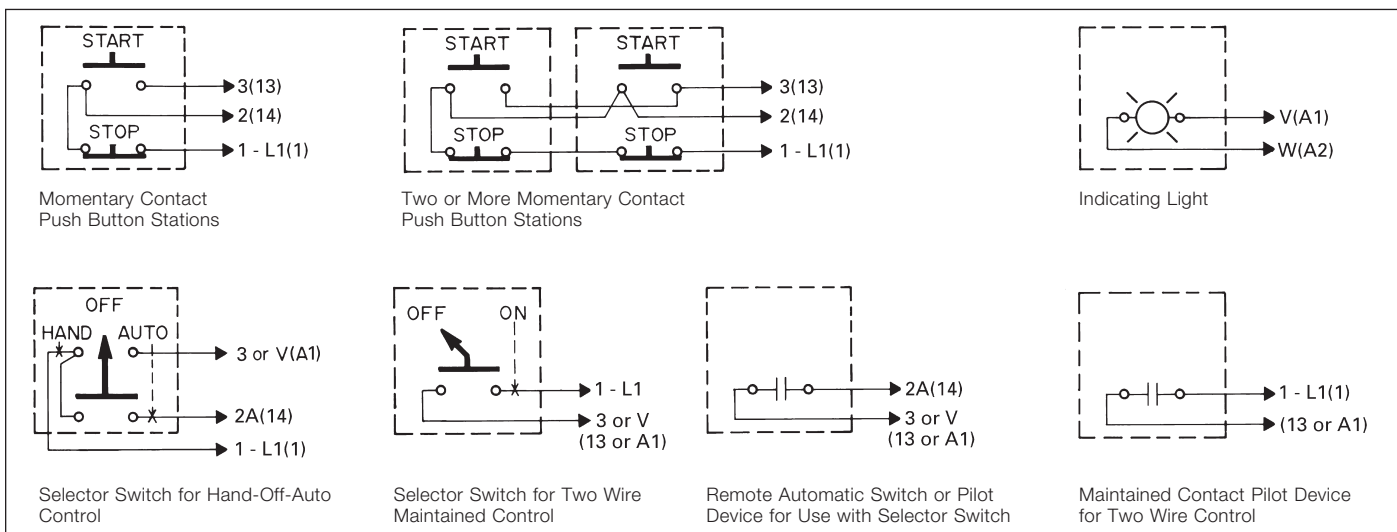

Reversing Pilot Control For Separate control voltage source remove Jumper A shown in individual wiring diagrams. Connect separate voltage source to terminal 1 on the pilot device as shown and to the terminal **X2** on the overload relay, or **W(A2)** on the coil if there is no overload.

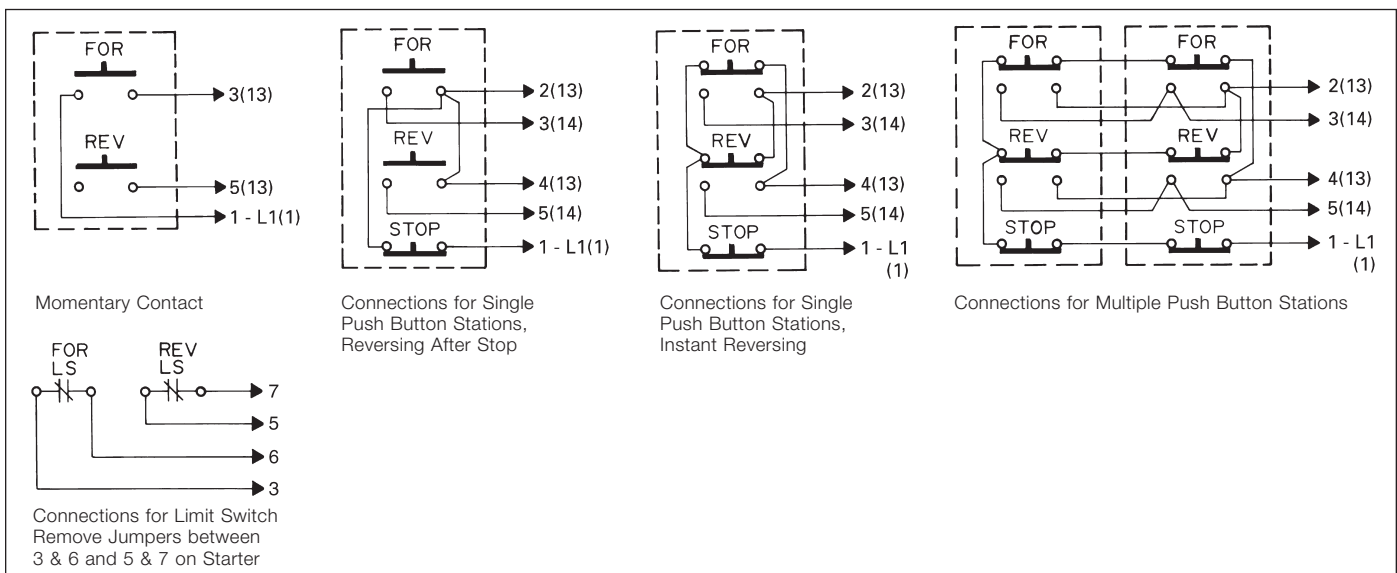

Appendix

International Control Equipment (IEC)

Quick reference list

Siemens is a manufacturer of equipment for the global market and manufactures products for global applications. The products listed in Sections 1 through 18 of this catalog are the products best suited for application in the U.S., Canada and Mexico.

There are a host of other Industrial Control products that can be made available for export applications or for replacement in OEM equipment imported in to the U.S. The most common Siemens components are listed in the table below. We refer to these as Industrial Control Equipment components or ICE products.

If you are trying to identify a Siemens ID that is not listed in the Catalog Number Index on pages 0/12 to 0/15 of this catalog or in the table below, please contact our Call Center at 800-241-4453 or 423-262-5700. The Siemens Call Center maintains an extensive data base on all Siemens Operating Companies, and they can direct you for the appropriate support.

Catalog Number Prefix	Description	Catalog Number Prefix	Description	Catalog Number Prefix	Description
2CC	Low-Pressure Axial Ventilator Fan	3WY3	3WN Accessories	4FL	Transformer Voltage Regulator
2CF7	Medium-Pressure Radial-flow Fan	4AC	Bell transformers, power supply units	4NC	Window-type Current Transformer
2CQ	Medium-Pressure Axial Ventilator Fan	4AJ	Standard Transformers	4PK	Reactance coils with layer winding of copper flat wire
2CT	Low-Pressure Axial Ventilator Fan	4AM	Control Transformer	5SA	DIAZED Fuse Links (E16) Miniature Fuses ¹⁾
3KA	Disconnect Switch	4AN	Single-phase transformers YUI 1 (UI)	5SB	DIAZED Fuse Links, Size II and III ¹⁾
3KE	Disconnect Switch	4AP	Transformer for rectifier operation	5SC	DIAZED Fuse Links, Size IV and V ¹⁾
3KL	Load Disconnect Switch w/Fuses	4AT	Safety Isolation Transformer, 1 phase	5SD	DIAZED Fuses
3KM	Load Disconnect Switch w/Fuses	4AU	Safety Isolation Transformer, 3 phase	5SE	Fuses ¹⁾
3KX	3KE4 Accessories	4AV	Special Transformers and DC power supplies	5SF	DIAZED Fuse Base
3KY	3KL Accessories	4AW	Ring core transformers	5SG	NEOZED & MINIZED Fuse Disconnectors
3NA	LV HRC Fuses	4AX	Non-Siemens transformers	5SH	DIAZED Fuse Accessories
3NC	SITOR Semiconductor fuse-links to 1000 V ¹⁾	4AY	Transformer housings, accessories and spare parts	5SM	Residual Current Protective Devices ¹⁾
3ND1	LV HRC Fuses	4BT	Transformer > 16 kVA, 1 Phase	5SQ	Miniature Circuit Breaker
3ND2	LV HRC Fuses	4BU	Transformer > 16 kVA, 3 Phase	5SU	Ground Fault and Line-Prot. Circuit Breaker
3NE	SITOR Semiconductor fuse-links to 2500 V ¹⁾	4BV	Special Transformers	5SV8	SFJ Fault and Line-Prot. Circuit Breaker
3NG1	LV HRC Fuses	4BX	Transformer, 3-phase	5SW	Wall Enclosure
3NH	Fuse Bases	4CH	Variac 1 Phase	5SZ	Ground Fault Circuit Breakers
3NJ	Fused Disconnect Switch	4CJ	Variac 3 Phase	5TE	Toggle Switch
3NP	Fused Disconnect Switch	4CP	Pillar-type, Variac, 1ph	5TG	Signal Light
3NW1	Fuse Material to BS and NF Standards ¹⁾	4CQ	Pillar-type, Variac, 3ph	5TT	Switch Relay
3NW6	Cylindrical Fuses	4EA	Reactance Coils with Iron-Core Reactors	7KM	Meters
3NW8	Fuse Material to BS and NF Standards	4EF	Reactance Coils with Iron-Core Reactors	7KT	Time meters, impulsing meters and accessories
3NX	Accessories and spare parts for NH-fuses	4EJ	Reactance Coils with Iron-Core Reactors	7LF	Digital time switches and accessories
3NY	3NP Accessories	4EM	Single-phase reactance coils YEI 1 (EI)	7LQ	Quarz-controlled time switches
3TK	Specialty Contactor	4EN9	Choke	7PV	Timers
3UL22	Summation Current Transformers	4EP	Line Reactor	7ZX	Instruction Manual ¹⁾
3VU2	Phase Out Announced	4ET	Single-phase reactance coils YUI 1 (UI)	8JH	Distribution Enclosure Accessories
3VX	Circuit Breaker Accessories and Components	4EU	Three-phase reactance coils YUI 2 (3UI)	8UB	Handle Accessories
3WX	3W Accessories	4EV	RFI Suppression Choke	8WC	Distribution System Accessories
3WY1	3WF Accessories	4FB	Power supplies	8ZX	Instruction Sheets ¹⁾
3WY2	3WE Accessories	4FK	Magnetic Voltage Regulator 1 phase	LZX	Plug-in Relays ¹⁾

1) Standard Control Product - Not Considered ICE Product.

Spring Loaded Terminals

As an alternative to screw-type terminals, many products may be supplied with spring loaded terminals. With this screwless connection technique, the wires are clamped securely against shock and vibration by a spring clamp. Solid, stranded and finely-stranded wires can be connected with or without end sleeves.

Each terminal connection is equipped with two independently operated spring clamps. Each spring can accept one wire. The clamping force of the spring automatically adjusts to the size of the wire and compensates for

any deformation of the wire, such as settling of the strands. The flat clamping face of the spring presses the wire against the current bar without damaging the wire. To prevent stranded or finely-stranded wire from being divided, the end can be tinned or amalgamated using ultrasound.

The terminal is opened by inserting the screwdriver. The wire is then inserted and will remain clamped after the screwdriver is removed (see below). The chromium-nickel steel of the spring clamp provides corrosion-resistant contact of the wire-end in the clamp.

Advantages:

- Quick: The connection is made easily without the need to add on wire end sleeves or torque down terminal screws—reducing wiring time
- Reliable: The terminal is gas-tight and resistant to shock and vibration—for maximum contact reliability
- Maintenance-free: With the spring loaded terminals, there is no need to inspect the connections following transport—eliminating time-consuming and costly inspection

Step 1:
Insert screwdriver;
spring opens.

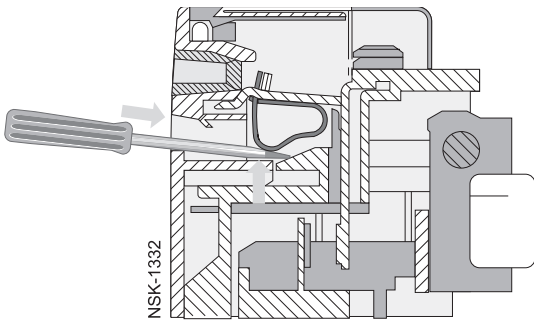

Step 2:
The screwdriver holds the spring open;
insert the wire.

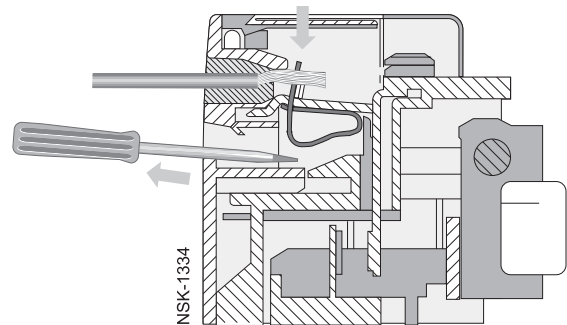

Step 3:
Remove the screwdriver; the spring
closes and the wire is securely clamped.

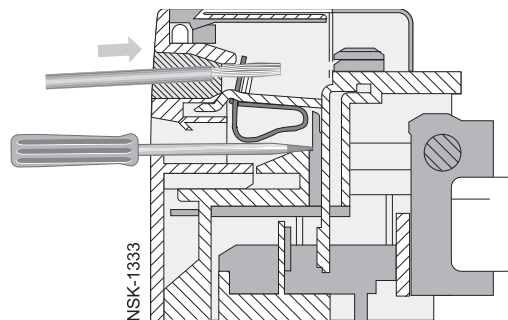

Appendix

Siemens Industry, Inc. (Seller)

Standard terms and conditions of sale

1. APPLICABLE TERMS. These terms govern the sale of Products by Siemens. Whether these terms are included in an offer or an acceptance by Siemens, such offer or acceptance is conditioned on Buyer's assent to these terms. Any additional, different or conflicting terms contained in Buyer's request for proposal, specifications, purchase order or any other written or oral communication from Buyer shall not be binding in any way on Siemens. Siemens failure to object to any such additional, different or conflicting terms shall not operate as a waiver of these terms.

2. PRICING & PAYMENT. The prices shall be: (a.) as stated in Siemens' proposal, or if none are stated, (b.) Siemens' standard prices in effect at the time of release for shipment. In the event of a price increase or decrease, the price of Products on order shall be adjusted to reflect such increase or decrease. This does not apply to a shipment held by request of Buyer. Products already shipped are not subject to price increase or decrease.

Discounts, if any, are as specified on the latest discount sheets issued from time to time. Cash discounts are not applicable to notes or trade acceptances, to pre-paid transportation charges when added to Siemens' invoices or to discountable items if there are undisputed past due items on the account. Cash discounts shall only be allowed on that portion of the invoice paid within the normal discount period.

(a) Payment - Unless otherwise stated, all payments shall be net 30 days from invoice date payable in United States Dollars.

(b) Credit Approval - All orders are subject to credit approval by Siemens. The amount of credit or terms of payment may be changed or credit withdrawn by Siemens at any time for any reason without advance notice. Siemens may, in its discretion, withhold further manufacture or shipment; require immediate cash payments for past and future shipments; or require other security satisfactory to Siemens before further manufacture or shipment is made; and may, if shipment has been made, recover the Products from the carrier, pending receipt of such assurances.

(c) Installment Shipment - If these terms require or authorize delivery of Products in separate shipments to be separately accepted by Buyer, Buyer may only refuse such portion of such shipment that fails to comply with the requirements of these terms. Buyer may not refuse to receive any lot or portion of hereunder for failure of any other lot or portion of a lot to be delivered or to comply with these terms, unless such right of refusal is expressly provided for on the face hereof. Buyer shall pay for each lot in accordance with the terms hereof. Payment shall be made for the Products without regard to whether Buyer has made or may make any inspection of the Products. Products held for Buyer are at Buyer's sole risk and expense.

(d) Taxes, Shipping, Packing, Handling - Except to the extent expressly stated in these terms, Siemens' prices do not include any freight, storage, insurance, taxes, excises, fees, duties or other government charges related to the Product, and Buyer shall pay such amounts or reimburse Siemens for any amounts Siemens pays. If Buyer claims a tax or other exemption or direct payment permit, it shall provide Siemens with a valid exemption certificate or permit and indemnify, defend and hold Siemens harmless from any taxes, costs and penalties arising out of same. Siemens' prices include the costs of its standard domestic packing only. Any deviation from this standard packing (domestic or export), including U.S. Government sealed packing, shall result in extra charges. To determine such extra charges, consult Siemens' sales offices. Any and all increases, changes, adjustments or surcharges (including, without limitation, fuel surcharges) which may be in connection with the freight charges, rates or classification included as part of these terms, shall be for the Buyer's account. Orders of less than \$400 are subject to a \$25 handling fee.

(e) Finance Charge - Buyer agrees to pay FINANCE CHARGES on the unpaid balance of all overdue invoices, less any applicable payments and credits, from the date each invoice is due and payable at an ANNUAL PERCENTAGE RATE of EIGHTEEN PERCENT (18%), or the highest applicable and lawful rate on such unpaid balance, whichever is lower.

(f) Disputed Invoice - In the event Buyer disputes any portion or all of an invoice, it shall notify Siemens in writing of the amount in dispute and the reason for its disagreement within 21 days of receipt of the invoice. The undisputed portion shall be paid when due, and FINANCE CHARGE on any unpaid portion shall accrue, from the date due until the date of payment, to the extent that such amounts are finally determined to be payable to Siemens.

(g) Collection - Upon Buyer's default of these terms, Siemens may, in addition to any other rights or remedies at contract or law, subject to any cure right

of Buyer, declare the entire balance of Buyer's account immediately due and payable or foreclose any security interest in Products delivered. If any unpaid balance is referred for collection, Buyer agrees to pay Siemens, to the extent permitted by law, reasonable attorney fees in addition to all damages otherwise available, whether or not litigation is commenced or prosecuted to final judgment, plus any court costs or expenses incurred by Siemens, and any FINANCE CHARGES accrued on any unpaid balance owed by Buyer.

3. DELIVERY; TITLE; RISK OF LOSS. Product shall be delivered F.O.B. Siemens point of shipment with title to the Product and risk of loss or damage for the Product passing to Buyer at that point. Buyer shall be responsible for all transportation, insurance and related expenses including any associated taxes, duties or documentation. Siemens may make partial shipments. Shipping dates are approximate only and Siemens shall not be liable for any loss or expense (consequential or otherwise) incurred by Buyer or Buyer's customers if Siemens fails to meet the specified delivery schedule. A 5% handling charge will be added to the price for all Product furnished from a local branch.

4. DEFERMENT AND CANCELLATION. Buyer shall have no deferment rights and Buyer shall be liable for cancellation charges, which shall include without limitation a) payment of the full product price for any finished Product or works in progress; b) payment for raw materials ordered pursuant to a firm purchase order; and c) such other direct costs incurred by Siemens as a result of such cancellation.

5. FORCE MAJEURE / DELAYS. If Siemens suffers delay in performance due to any cause beyond its reasonable control, including without limitation acts of God, strikes, labor shortage or disturbance, fire, accident, war or civil disturbance, delays of carriers, failure of normal sources of supply, or acts of government, the time of performance shall be extended a period of time equal to the period of the delay and its consequences. Siemens will give to Buyer notice within a reasonable time after Siemens becomes aware of any such delay

6. BUYER'S REQUIREMENTS. Timely performance by Siemens is contingent upon Buyer's supplying to Siemens all required technical information and data, including drawing approvals, and all required commercial documentation.

7. LIMITED WARRANTY. (a.) Limited Product Warranty Statements. For each Product purchased from Siemens or an authorized reseller, Siemens makes the following limited warranties: (i) the Product is free from defects in material and workmanship, (ii) the Product materially conforms to Siemens' specifications that are attached to, or expressly incorporated by reference into, these terms, and (iii) at the time of delivery, Siemens has title to the Product free and clear of liens and encumbrances (collectively, the "Limited Warranties"). Warranties with respect to software which may be furnished by Seller as part of the Product, if any, are expressly set forth elsewhere in these terms. The Limited Warranties set forth herein do not apply to any software furnished by Siemens. If software is furnished by Siemens, then the attached Software License/Warranty Addendum shall apply.

(b.) Conditions to the Limited Warranties. The Limited Warranties are conditioned on (i) Buyer storing, installing, operating and maintaining the Product in accordance with Siemens' instructions, (ii) no repairs, modifications or alterations being made to the Product other than by Siemens or its authorized representatives, (iii) using the Product within any conditions or in compliance with any parameters set forth in specifications that are attached to, or expressly incorporated by reference into, these terms, (iv) Buyer discontinuing use of the Product after it has, or should have had, knowledge of any defect in the Product, (v) Buyer providing prompt written notice of any warranty claims within the warranty period described below, (vi) at Siemens' discretion, Buyer either removing and shipping the Product or non-conforming part thereof to Siemens, at Buyer's expense, or Buyer granting Siemens access to the Products at all reasonable times and locations to assess the warranty claims, and (vii) Buyer not being in default of any payment obligation to Siemens under these terms.

(c.) Exclusions from Limited Warranty Coverage. The Limited Warranties specifically exclude any equipment comprising part of the Product that is not manufactured by Siemens or not bearing its nameplate. To the extent permitted, Siemens hereby assigns any warranties made to Siemens for such equipment. Siemens shall have no liability to Buyer under any legal theory for such equipment or any related assignment of warranties. Additionally, any Product that is described as being experimental, developmental, prototype, or pilot is specifically excluded from the Limited Warranties and is provided to Buyer "as is" with no warranties of any kind. Also excluded from the Limited Warranties are normal wear and tear items including any expendable items that comprise part of the Product, such as fuses and light bulbs and lamps.

(d.) Limited Warranty Period. Buyer shall have 12 months from initial operation of the Product or 18 months from shipment, whichever occurs first, to provide Siemens with prompt, written notice of any claims of breach of the Limited Warranties. Continued use or possession of the Product after expiration of the warranty period shall be conclusive evidence that the Limited Warranties have been fulfilled to the full satisfaction of Buyer, unless Buyer has previously provided Siemens with notice of a breach of the Limited Warranties.

(e.) Remedies for Breach of Limited Warranty. Buyer's sole and exclusive remedies for any breach of the Limited Warranties are limited to Siemens' choice of repair or replacement of the Product, or non-conforming parts thereof, or refund of all or part of the purchase price. The warranty on repaired or replaced parts of the Product shall be limited to the remainder of the original warranty period. Unless otherwise agreed to in writing by Siemens, (i) Buyer shall be responsible for any labor required to gain access to the Product so that Siemens can assess the available remedies and (ii) Buyer shall be responsible for all costs of installation of repaired or replaced Products. All exchanged Products replaced under this Limited Warranty will become the property of Siemens.

(f.) Transferability. The Limited Warranties shall be transferable during the warranty period to the initial end-user of the Product.

THE LIMITED WARRANTIES SET FORTH IN THIS SECTION ARE SIEMENS' SOLE AND EXCLUSIVE WARRANTIES AND ARE SUBJECT TO THE LIMITS OF LIABILITY SET FORTH IN SECTION 8 BELOW. SIEMENS MAKES NO OTHER WARRANTIES, EXPRESS OR IMPLIED, INCLUDING, WITHOUT LIMITATION, WARRANTIES OF MERCHANTABILITY OR FITNESS FOR A PARTICULAR PURPOSE, COURSE OF DEALING AND USAGE OF TRADE.

8. LIMITATION OF LIABILITY. NEITHER SIEMENS, NOR ITS SUPPLIERS, SHALL BE LIABLE, WHETHER IN CONTRACT, WARRANTY, FAILURE OF A REMEDY TO ACHIEVE ITS INTENDED OR ESSENTIAL PURPOSES, TORT (INCLUDING NEGLIGENCE), STRICT LIABILITY, INDEMNITY OR ANY OTHER LEGAL THEORY, FOR LOSS OF USE, REVENUE, SAVINGS OR PROFIT, OR FOR COSTS OF CAPITAL OR OF SUBSTITUTE USE OR PERFORMANCE, OR FOR INDIRECT, SPECIAL, LIQUIDATED, PUNITIVE, EXEMPLARY, COLLATERAL, INCIDENTAL OR CONSEQUENTIAL DAMAGES, OR FOR ANY OTHER LOSS OR COST OF A SIMILAR TYPE, OR FOR CLAIMS BY BUYER FOR DAMAGES OF BUYER'S CUSTOMERS. SIEMENS' MAXIMUM LIABILITY UNDER THIS CONTRACT SHALL BE THE ACTUAL PURCHASE PRICE RECEIVED BY SIEMENS FOR THE PRODUCT AT ISSUE OR ONE MILLION DOLLARS, WHICHEVER IS LESS. BUYER AGREES THAT THE EXCLUSIONS AND LIMITATIONS SET FORTH IN THIS ARTICLE ARE SEPARATE AND INDEPENDENT FROM ANY REMEDIES WHICH BUYER MAY HAVE HEREUNDER AND SHALL BE GIVEN FULL FORCE AND EFFECT WHETHER OR NOT ANY OR ALL SUCH REMEDIES SHALL BE DEEMED TO HAVE FAILED OF THEIR ESSENTIAL PURPOSE. THESE LIMITATIONS OF LIABILITY ARE EFFECTIVE EVEN IF SIEMENS HAS BEEN ADVISED BY THE BUYER OF THE POSSIBILITY OF SUCH DAMAGES.

9. PATENT AND COPYRIGHT INFRINGEMENT. Siemens will, at its own expense, defend or at its option settle any suit or proceeding brought against Buyer in so far as it is based on an allegation that any Product (including parts thereof), or use thereof for its intended purpose, constitutes an infringement of any United States patent or copyright, if Siemens is promptly provided notice and given authority, information, and assistance in a timely manner for the defense of said suit or proceeding. Siemens will pay the damages and costs awarded in any suit or proceeding so defended. Siemens will not be responsible for any settlement of such suit or proceeding made without its prior written consent. In case the Product, or any part thereof, as a result of any suit or proceeding so defended is held to constitute infringement or its use by Buyer is enjoined, Siemens will, at its option and its own expense, either: (a) procure for Buyer the right to continue using said Product; (b) replace it with substantially equivalent non-infringing Product; or (c) modify the Product so it becomes non-infringing.

Siemens will have no duty or obligation to Buyer under this Article to the extent that the Product is (a) supplied according to Buyer's design or instructions wherein compliance therewith has caused Siemens to deviate from its normal course of performance, (b) modified by Buyer or its contractors after delivery, (c) combined by Buyer or its contractors with devices, methods, systems or processes not furnished hereunder and by reason of said design, instruction, modification, or combination a suit is brought against Buyer. In addition, if by reason of such design, instruction, modification or combination, a suit or proceeding is brought against Siemens, Buyer shall protect Siemens in the same manner and to the same extent that Siemens has agreed to protect Buyer under the provisions of the Section above.

THIS ARTICLE IS AN EXCLUSIVE STATEMENT OF ALL THE DUTIES OF THE PARTIES RELATING TO PATENTS AND COPYRIGHTS, AND DIRECT OR CONTRIBUTORY PATENT OR COPYRIGHT AND OF ALL THE REMEDIES OF BUYER RELATING TO ANY CLAIMS, SUITS, OR PROCEEDINGS INVOLVING PATENTS AND COPYRIGHTS.

10. COMPLIANCE WITH LAWS. Buyer agrees to comply with all applicable laws and regulations relating to the purchase, resale, exportation, transfer, assignment, disposal or use of the goods.

11. CHANGES IN WORK. Siemens shall not implement any changes in the scope of work unless Buyer and Siemens agree in writing to the details of the change and any resulting price, schedule or other contractual modifications. Any change to any law, rule, regulation, order, code, standard or requirement which requires any change hereunder shall entitle Siemens to an equitable adjustment in the prices and any time of performance.

12. NON-WAIVER OF DEFAULT. Each shipment made hereunder shall be considered a separate transaction. In the event of any default by Buyer, Siemens may decline to make further shipments. If Siemens elects to continue to make shipments, Siemens' actions shall not constitute a waiver of any default by Buyer or in any way affect Siemens' legal remedies for any such default. Any waiver of Siemens to require strict compliance with the provisions of this contract shall be in writing and any failure of Siemens to require such strict compliance shall not be deemed a waiver of Siemens' right to insist upon strict compliance thereafter.

13. FINAL WRITTEN AGREEMENT; MODIFICATION OF TERMS. These terms, together with any quotation, purchase order or acknowledgement issued or signed by Siemens, comprise the complete and exclusive agreement between the parties (the "Agreement") and supersede any terms contained in Buyer's documents, unless separately signed by Siemens. These terms may only be modified by a written instrument signed by authorized representatives of both parties.

14. ASSIGNMENT. Neither party may assign the Agreement, in whole or in part, nor any rights or obligations hereunder without the prior written consent of the other; provided however that Siemens may assign its rights and obligations under these terms to its affiliates and Siemens may grant a security interest in the Agreement and/or assign proceeds of the Agreement without Buyer's consent.

15. APPLICABLE LAW AND JURISDICTION. These terms are governed and construed in accordance with the laws of the State of Delaware, without regard to its conflict of laws principles. The application of the United Nations Convention on Contracts for the International Sale of Goods is excluded. BUYER WAIVES ALL RIGHTS TO A JURY TRIAL IN ANY ACTION OR PROCEEDING RELATED IN ANY WAY TO THESE TERMS.

16. SEVERABILITY. If any provision of these terms is held to be invalid, illegal or unenforceable, the validity, legality and enforceability of the remaining provisions will not in any way be affected or impaired, and such provision will be deemed to be restated to reflect the original intentions of the parties as nearly as possible in accordance with applicable law.

17. EXPORT COMPLIANCE. Buyer acknowledges that Siemens is required to comply with applicable export laws and regulations relating to the sale, exportation, transfer, assignment, disposal, and usage of the Products provided under the Contract, including any export license requirements. Buyer agrees that such Products shall not at any time directly or indirectly be used, exported, sold, transferred, assigned or otherwise disposed of in a manner which will result in non-compliance with such applicable export laws and regulations. It shall be a condition of the continuing performance by Siemens of its obligations hereunder that compliance with such export laws and regulations be maintained at all times. BUYER AGREES TO INDEMNIFY AND HOLD SIEMENS HARMLESS FROM ANY AND ALL COSTS, LIABILITIES, PENALTIES, SANCTIONS AND FINES RELATED TO NON-COMPLIANCE WITH APPLICABLE EXPORT LAWS AND REGULATIONS.

Appendix

Notes