

Combination Motor Control Units

Motor control centers principally contain combination motor control units. NEMA ICS-1-322 states that . . .

A combination motor control unit shall include externally operable circuit disconnecting means, branch-circuit overcurrent protection, and a magnetic motor controller with associated auxiliary devices when used. The disconnecting means and branch-circuit overcurrent protection shall consist of a fusible disconnecting device or circuit breaker. If the latter is used, it shall either be an inverse time (thermal-magnetic or dual magnetic) or an instantaneous magnetic type. The motor controller shall include motor and branch-circuit protection unless equivalent protection is otherwise provided.

A combination motor control unit takes all the elements required to control an AC motor and combines them into one unit. The combination motor control unit in the following example uses a molded case circuit breaker to provide circuit disconnecting means and branch-circuit overcurrent protection. The circuit breaker is opened and closed using the operating handle located on the front of the unit. The magnetic motor starter is used to start and stop an AC motor and provide overcurrent protection for the motor. Pilot devices, located on the door, serve to provide an operator means to start and stop the motor as well as provide visual indication of the motor's status.

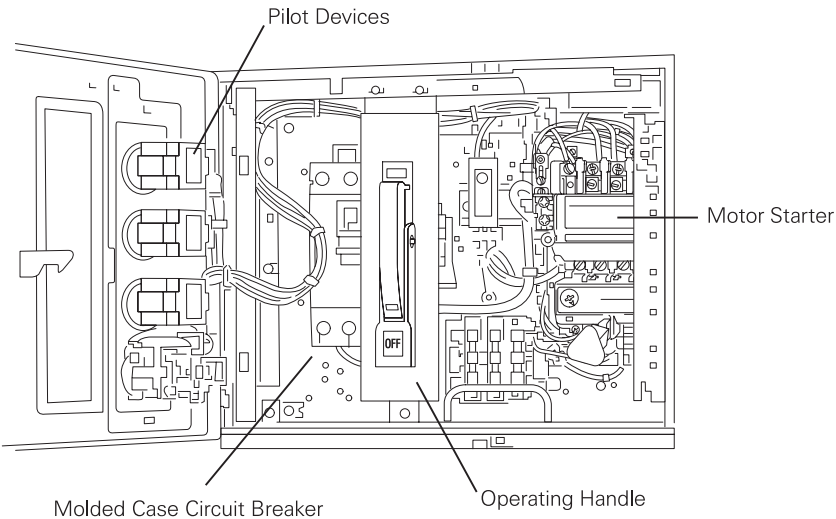

Vertical Space

Most vertical sections provide 72" of vertical space for the combination motor control units. As many sections as needed will be assembled together to contain all of the required combination motor control units and other equipment. Wireways run horizontally across the top and bottom of all of the sections. A vertical wireway is provided in each vertical section.

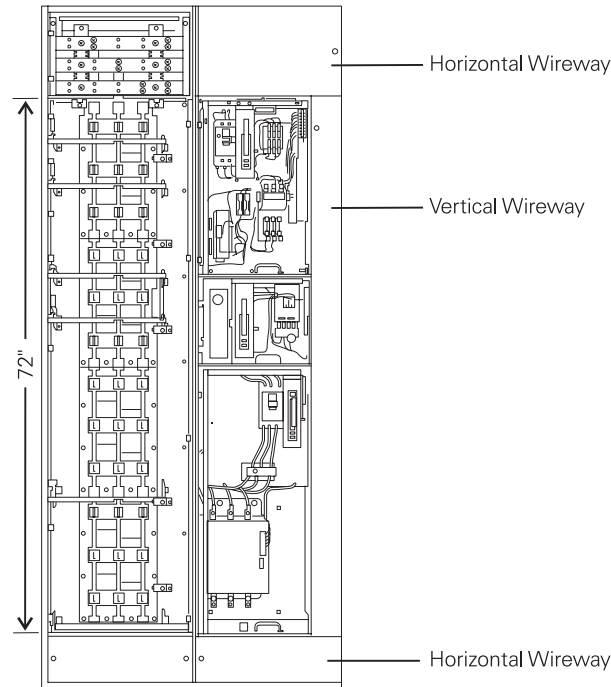

Dimensions

Combination motor control units are designed to fit into modular compartments. Typically, the minimum height of a combination motor control unit is 12", increasing in 6" increments (12", 18", 24", 30", up to 72") as needed. Six combination motor control units that are 12" high will fit in 72" of vertical space.

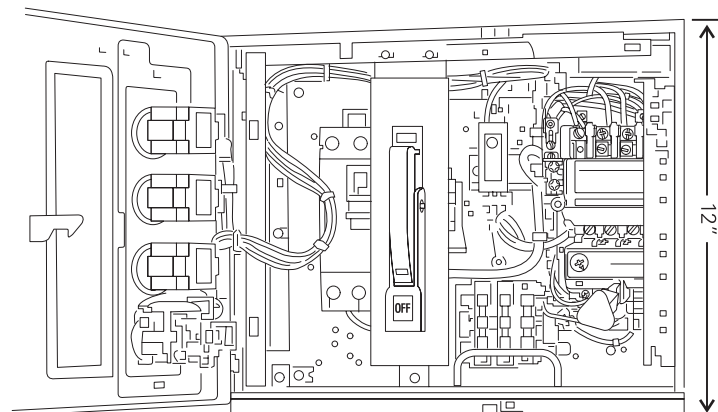

Installation and Removal

To simplify installation and removal, combination motor control units are provided with self-aligning copper stabs on the back of the control unit. An optional ground bus stab is used when a vertical ground bus is supplied. A fixed mounting is used when the unit is physically too large for stabs or rated for greater than 250 amps.

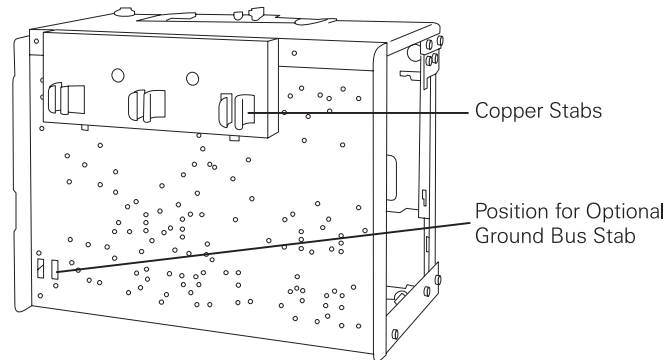

These stabs engage the vertical bus bars, making the electrical connection to the control unit. Siemens incorporates a flat vertical bus bar to ensure positive connection between the stab and the bus bar.

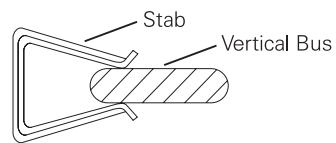

Unit Supports

Combination motor control units are supported in the motor control center on shelf brackets. The brackets can be easily moved to accommodate different size units. The brackets guide the combination motor control unit to assure positive engagement with the vertical bus.

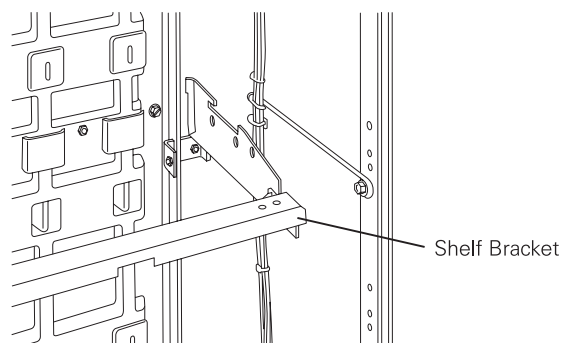

Review 3

1. Which of the following is not a part of the NEMA definition for motor control centers?
 - a. Floor-mounted assembly
 - b. Allowance for branch-circuit protection units
 - c. Common horizontal bus
 - d. Principally contains combination motor control units

2. The maximum shipping width of a motor control center is _____ inches.

3. Which of the following illustrates proper NEMA phase arrangement, as viewed from the front?

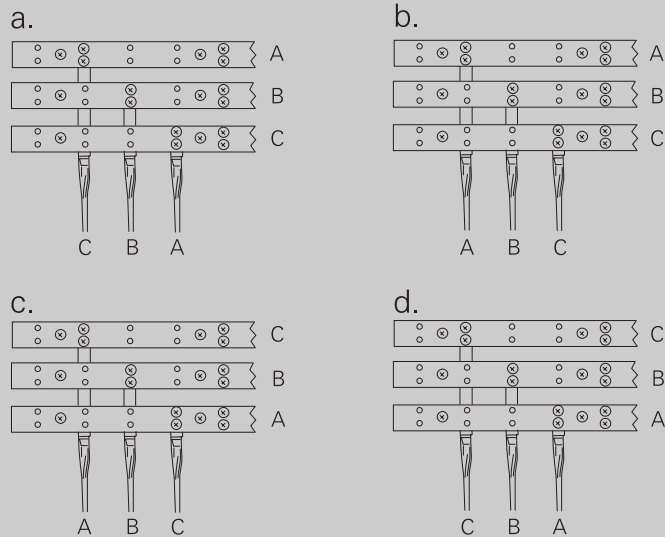

4. A distinguishing feature of motor control centers from panelboards is that motor control centers _____ .

- a. principally contain combination motor control units
- b. principally contain branch-circuit protection devices
- c. utilize both a horizontal and a vertical bus
- d. connect to three-phase power

5. According to NEMA's definition, which of the following is not part of a combination motor control unit?

- a. externally operable circuit disconnecting means
- b. common horizontal bus
- c. branch-circuit overcurrent protection
- d. magnetic motor controller

Motor Starters

The motor starter is the heart of the combination motor control unit. Motor starters consist of a contactor and an overload relay. The contactor portion of a motor starter provides the means to remotely start and stop a motor. The overload relay protects the motor from overload conditions.

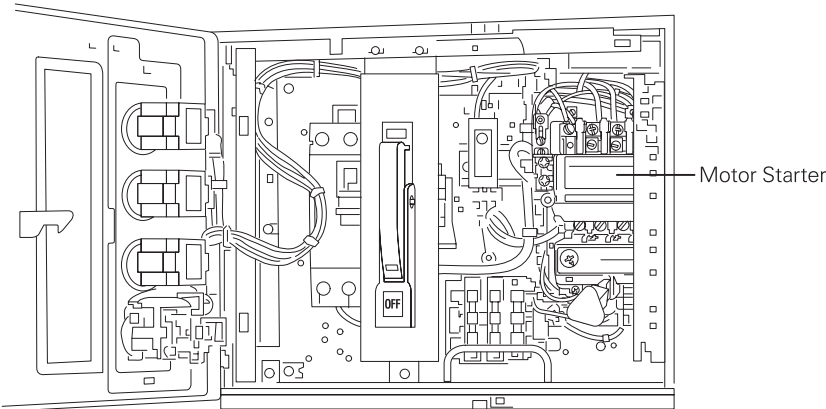

Overload Relay Trip Classes

Overload relays are rated by a trip class, which defines the length of time it will take for the relay to trip in an overload condition. The most common trip classes are Class 10, Class 20 and Class 30. Class 10, for example, has to trip the motor off line in 10 seconds or less at 600% of the full load amps. This is usually sufficient time for the motor to reach full speed. Many industrial loads, particularly high inertia loads, use Class 20.

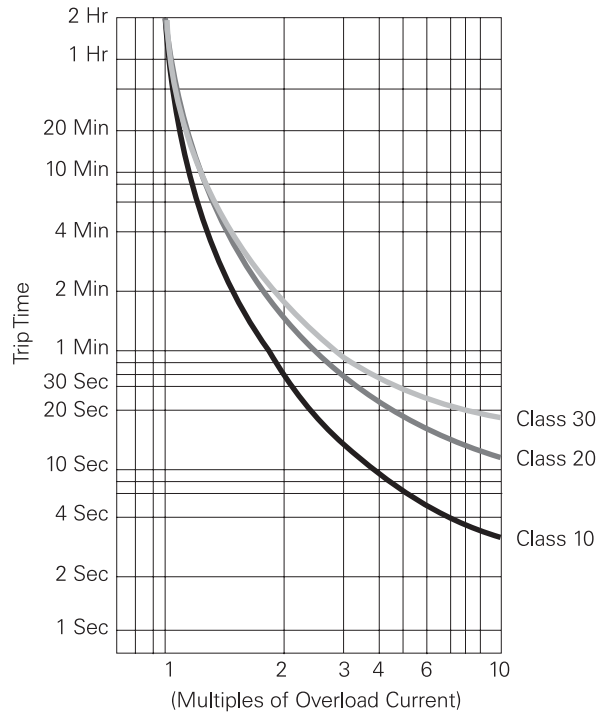

INNOVA PLUS

INNOVA PLUS™ is one type of starter which can be used in motor control centers. INNOVA PLUS starters are available with a Class 20 melting alloy type overload relay as standard. Class 10 or Class 20 ambient compensated or non-compensated bimetal overload relays are also available.

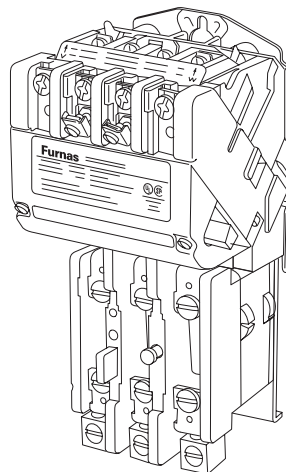

ESP100

The Furnas ESP100™ starters use the same contactor as the INNOVA PLUS™ starters. The ESP100 starters are supplied with a Class 10, 20, or 30 solid-state overload relay. The ESP100 also protects the motor against phase loss. The ESP100 trips within three seconds of loss of one of the power supply phases.

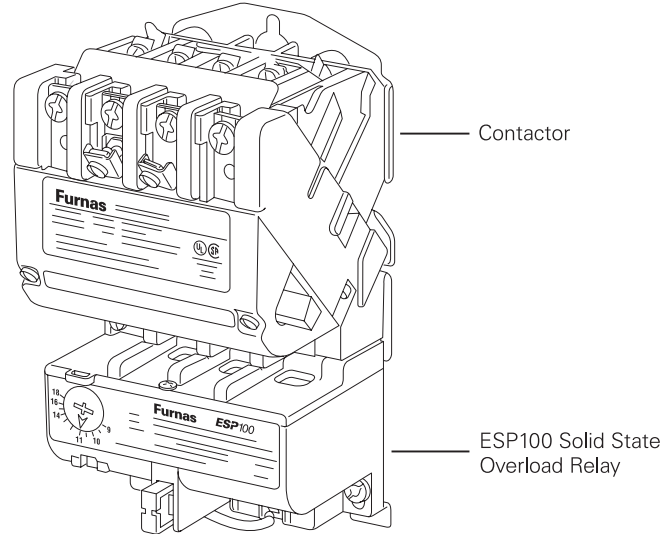

A single ESP100 overload relay replaces at least six size ranges of heaters. Instead of installing heaters the full load amperes (FLA) of the motor is set with a dial. The ESP100 overload relay protects 3Ø motors with FLA of ¼ ampere through 540 amperes. From ¼ ampere to 10 amperes the overload has a 4:1 FLA range; i.e. 2½ - 10 amperes. Above 10 amperes the range is 2:1. The ESP100 overload relay illustrated below, for example, is adjustable from 9 to 18 amperes.

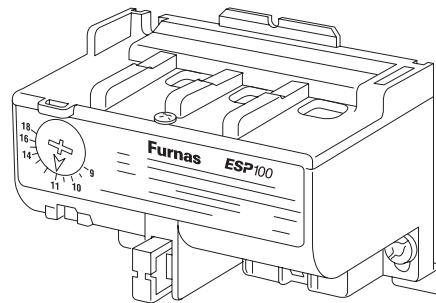

SAMMS

Siemens contactors can also be configured for use with the Siemens Advanced Motor Master System (SAMMS™). The SAMMS unit is a UL-recognized microprocessor-based motor control and protection device designed specifically for use in motor control centers. SAMMS provides microprocessor-based control and protection for all NEMA-rated low-voltage motors. Full communication options are available with SAMMS.

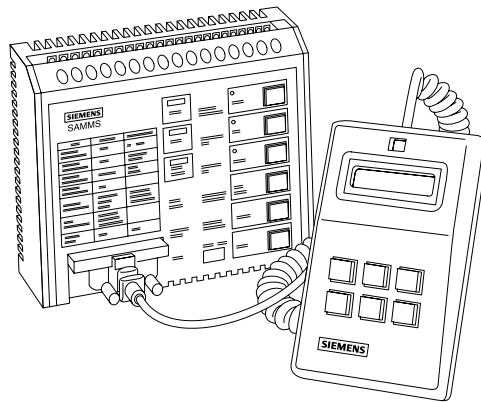

SIMOCODE-DP

SIMOCODE-DP is another motor protection and control device. In addition to NEMA class 5, 10, 15, 20, 25, and 30 overload trip characteristics SIMOCODE-DP provides current asymmetry (phase loss, phase imbalance, phase reversal), stalled rotor, over current, under current, and ground fault protection. In addition, inputs to SIMOCODE-DP devices can be used to monitor the status of digital signals typically associated motor control such as pilot devices and float or pressure switches. Outputs can be used to control contactors, relays, and pilot lights. Although SIMOCODE-DP is designed to work with PROFIBUS-DP, it will also work independent of a communication network.

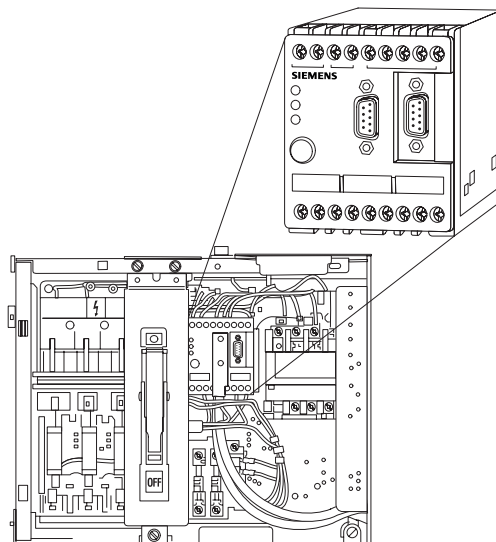

Starter Ratings

Starter contactors are rated according to size and type of load they handle. The International Electrotechnical Commission (IEC) and NEMA rate contactors and motor starters. IEC is associated with equipment sold in many countries including the United States. NEMA is primarily associated with equipment used in North America.

IEC ratings are maximum operational current as specified by the International Electrotechnical Commission. IEC does not specify sizes. The buyer needs to make clear which standards he expects to be met.

NEMA specifies sizes from size 00 to size 9, which cover the horsepower range from 2 HP to 1,600 HP at 460 volts.

Size of Controller	Horsepower at 460 V / 60 Hz
00	2
0	5
1	10
2	25
3	50
4	100
5	200
6	400
7	600
8	900
9	1600

Types of Starters

Starters can be configured to perform several different tasks. The following types of combination starters can be found in Siemens motor control centers:

- FVNR Full Voltage Non-Reversing
- FVR Full Voltage Reversing
- 2S1W Two Speed One Winding Reconnectable Consequent Pole Unit
- 2S2W Two Speed Two Winding
- PW Full Voltage Part Winding
- RVAT Reduced Voltage Auto-Transformer (Closed Transition)
- 3YD Wye Delta (Open or Closed Transition)

Pilot Devices

A number of pilot devices can be used on Siemens motor control centers. Pilot devices include pushbuttons, selector switches, and pilot lights.

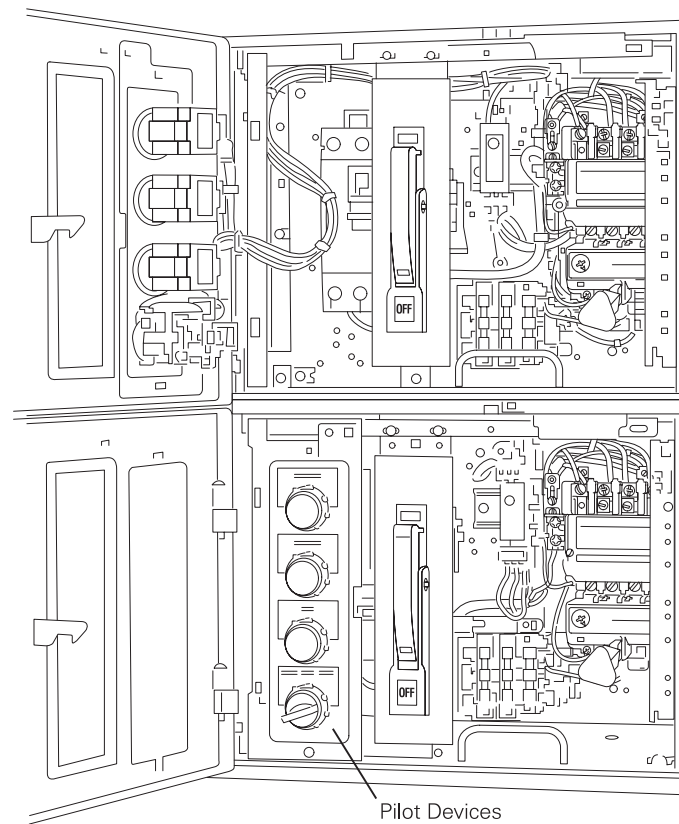

Pushbuttons

A pushbutton is a control device used to manually open and close a set of contacts. Pushbuttons are available in a flush mount, extended mount, with a mushroom head, illuminated, or non-illuminated. Pushbuttons come with either normally open, normally closed, or a combination contact block.

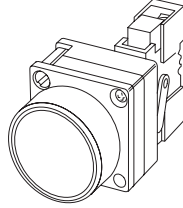

Siemens
22 mm Diameter
Pushbutton

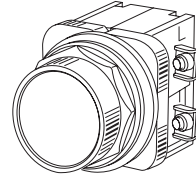

Siemens Furnas Control
30 mm Class 52
Pushbutton

Selector Switches

Selector switches are also used to manually open and close contacts. Selector switches can be maintained, spring return, or key operated. Selector switches are available in 2-, 3-, and 4-position types.

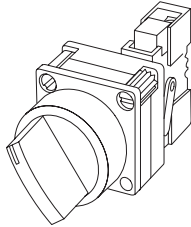

Siemens
22 mm Diameter
Selector Switch

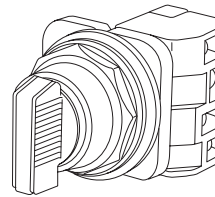

Siemens Furnas Control
30 mm Class 52
Selector Switch

Pilot Lights

Pilot lights provide visual information of the circuit's operating condition. Pilot lights are normally used for ON/OFF indication, caution, changing conditions, and alarm signaling. Pilot lights come with a color lens, such as red, green, amber, blue, white, or clear.

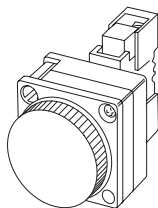

Siemens
22 mm Diameter
Pilot Light

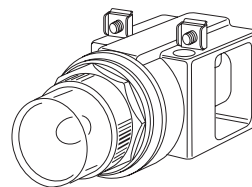

Furnas
30 mm Class 52
Pilot Light

Circuit Breakers

Circuit Breakers

Circuit breakers are typically used as disconnect devices in combination motor control units. Circuit breakers provide a manual means of energizing and de-energizing a circuit. In addition, circuit breakers provide automatic overcurrent protection of a circuit.

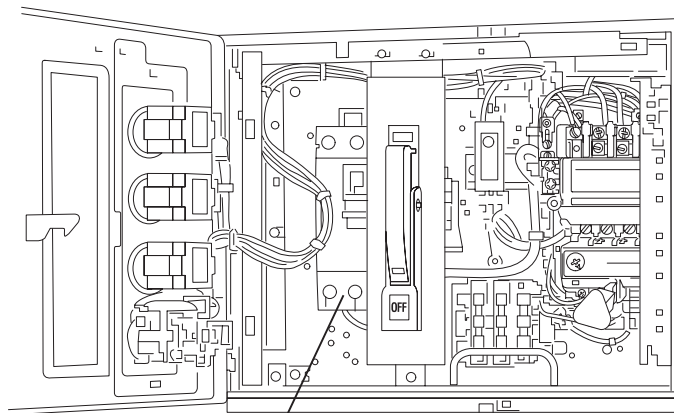

Molded Case Circuit Breaker

Siemens Sentron™ circuit breakers are available with ampere ratings up to 2000 amps. The Sentron series is also available in a digital version, referred to as Sensitrip III. Sensitrip III circuit breakers utilize a microcomputer which makes it possible to customize overcurrent protection which is matched exactly to the loads of an electrical system.

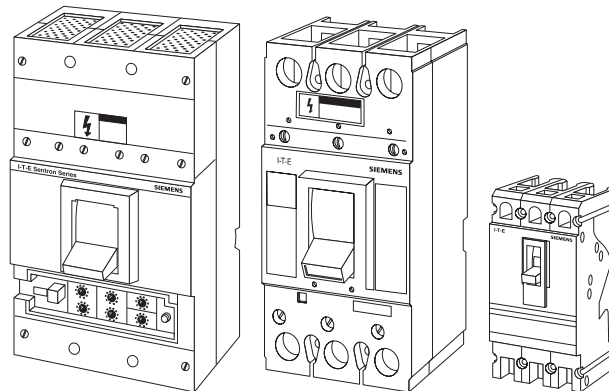

Sensitrip III

Sentron Series

Circuit Breaker Ratings

There are two types of circuit breakers that are typically used in motor control centers. Thermal-magnetic circuit breakers have both overload and instantaneous trip features. When an overload condition exists, the excess current generates heat, which is detected in the circuit breaker. After a short period of time, depending on the rating of the breaker and the amount of overload, the breaker will trip, disconnecting the load from the voltage source. If a short circuit occurs, the breaker responds instantaneously to the fault current and disconnects the circuit. This type of circuit breaker is used in applications where a motor starter is not used, such as a main disconnect for the MCC or a feeder tap unit. Thermal-magnetic circuit breakers are not used in conjunction with a motor starter.

Instantaneous trip-only circuit breakers are also referred to as magnetic only or Type ETI circuit breakers. Type ETI circuit breakers provide short circuit protection, but they do not provide overload protection. Type ETI circuit breakers are commonly used in combination motor control units where a motor starter, such as the Furnas ESP100, provides overload protection. ETI trip ranges are selected to meet maximum settings per *NEC*[®] table 430.52 and Article 430.52(C)(3). The instantaneous trip-only circuit breaker is factory set at the LOW position. In accordance with the *National Electrical Code*[®], the setting on an instantaneous trip circuit breaker may be increased over 800%, but cannot be increased over 1300% of full load amps for a NEMA B motor.

Other Types of Units in MCCs

Siemens motor control centers may include solid-state motor control devices, such as reduced-voltage soft-start controllers, variable frequency drives (VFD), and programmable logic controllers (PLCs). In addition, power meters can be used to measure real-time RMS values of phase currents, phase and line voltages, power usage, power factor, KW, frequency, and peak demand.

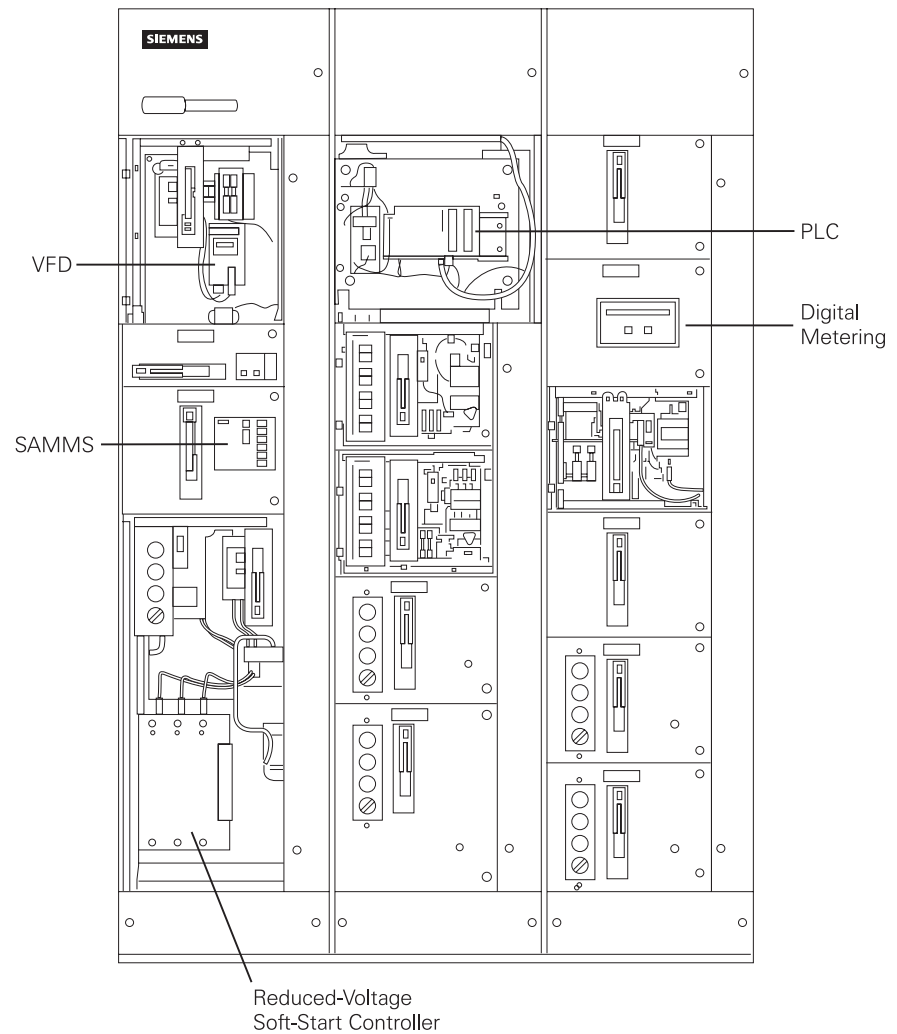

Reduced-Voltage Soft-Start Controllers

Reduced-voltage soft-start motor-starting controls, such as the SIRIUS or SIKOSTART reduced-voltage controllers, provides a smooth start while minimizing the high starting current and torque associated with across-the-line motor starting. SIRIUS controllers are available in models that will handle up to 60 HP at 460 volts and 75 HP at 575 volts. SIKOSTART are available in models that will handle up to 800 HP at 460 volts and 1000 HP at 575 volts.

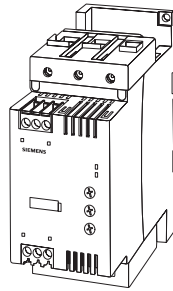

SIRIUS 3R

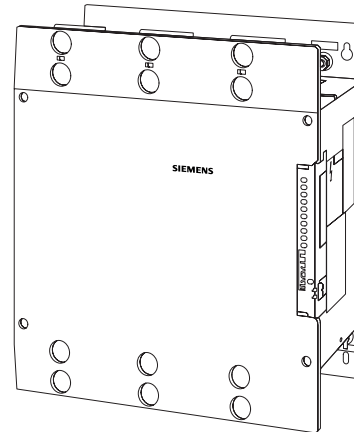

SIKOSTART

Variable Frequency Drives

Variable frequency drives are also referred to as AC drives. A typical AC drive receives 480 VAC, three-phase, 60 Hz input power which is used to start and stop a motor and control the operation of the motor throughout the speed range. A few features of Siemens AC drives include serial communication, DC injection braking, flux current control, vector control, pulsed resistor braking, and drive and motor protection. Siemens AC drives up to 250 HP at 480 VAC are available in MCCs.

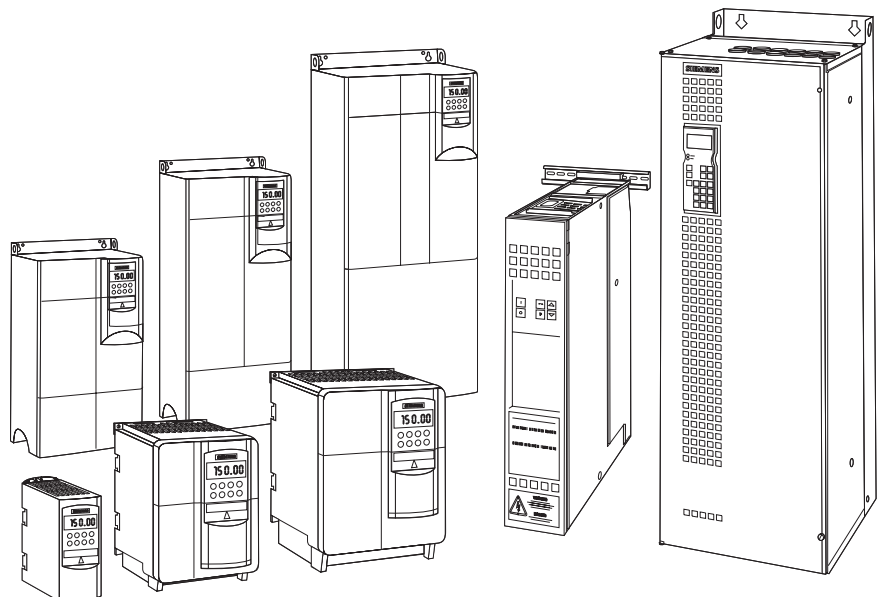

PLCs

PLCs consist of input modules or points, a central processing unit (CPU), and output modules or points. An input to a PLC may come from a variety of digital or analog signals from various field devices. The PLC converts the input signal into a logic signal that can be used by the CPU. Output modules convert control signals from the CPU into a digital or analog signal that can be used to control various field devices, such as a motor starter, an AC drive, or a reduced-voltage soft-start starter.

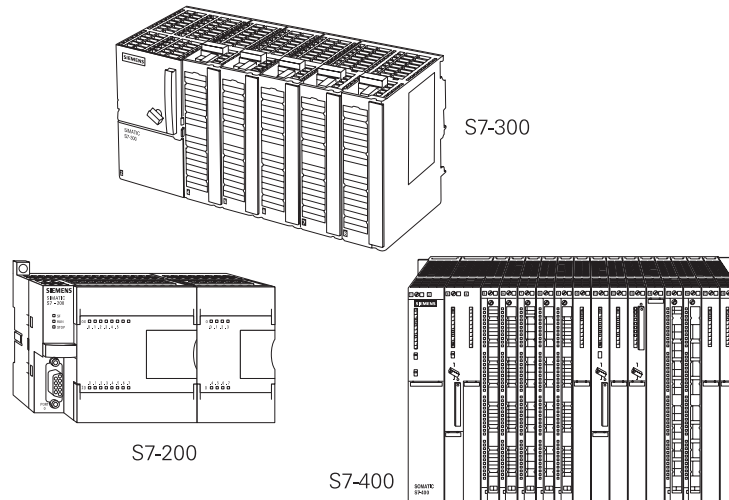

Digital Metering

Digital metering provides a highly accurate measure of current and power in industrial applications. Meters, such as the Siemens 9200, can replace multiple analog meters and have communication capabilities through the Siemens ACCESS™ system.

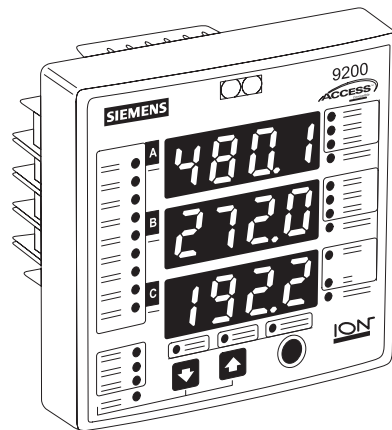

Other Units

There are other units that end up in MCCs such as relay panels, panelboards, and feeder-tap units. A feeder-tap unit, such as the one shown in the following illustration, is typically used to supply power to non-motor loads located downstream of the motor control center.

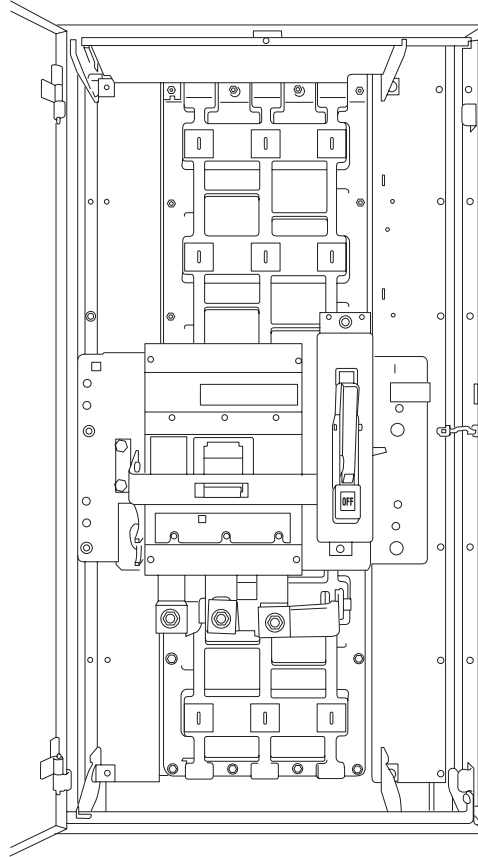

UL Marks

A motor control center has two UL marks. One is for the structure and bus, and one for each control unit. Some MCCs may contain special sections or units that have not been UL tested and therefore may not be able to carry the UL mark. Some municipalities may not allow devices that do not carry the UL mark.

Review 4

1. Class _____ provides the highest level of overload protection.
2. The ESP100 trips within _____ seconds of loss of one of the power-supply phases.
3. A size 5 controller is rated for _____ HP.
4. Which of the following devices can be used in a Siemens motor control center?
 - a. reduced-voltage starter
 - b. variable frequency drive
 - c. PLC
 - d. SAMMS
 - e. digital metering
 - f. all of the above
5. _____ and _____ are Siemens trade names for a reduced-voltage soft-start controller.